

HOME & GARDEN RANGE



Includes

BasicLine
by GRUNDFOS

One range of quality pumps for
the Home, Garden and Farm

be
think
innovate

GRUNDFOS 

WORKING IT OUT

WHAT PUMP DO I NEED? 1

Application	Household water supply
	Drainage
	Irrigation
	Water transfer
	Other
Water source	Above ground tank
	Underground tank
	River
	Dam
	Other
Power supply	240 V single phase
	415 V three phase
Water requirement	Household
	House only
	House and garden
	Showers (number)
	Sprinklers (number)
	Sprinklers (type)
	Evaporative airconditioner connected
	Irrigation
	Sprinklers (number)
	Sprinklers (type)
	Automatic Operation
	Manual Operation
	Drainage and Water transfer
	Lift from pump (A) to point of discharge (B)
Details of existing pipeline	Size (mm)
	Type (Polyethylene/PVC/Copper/Steel)
	Length (m)

HOW MUCH FLOW (Q)? 2

Water pressure systems	✓	
Weekend cottage		10 to 20 L/min
Small home		20 to 30 L/min
Average home		30 to 50 L/min
Large home		50 to 90 L/min
Average water consumption	No.	
Standard shower head		15 L/min
Water saving shower head		6-7 L/min
Household standard tap		10-15 L/min
Tap with aerator or flow restrictor		4-6 L/min
Lawn sprinkler		10-15 L/min
Drainage and effluent		See your Grundfos dealer

CALCULATE THE FLOW RATE 3

$$Q = (\quad) \text{ L/min}$$

HOW MUCH PRESSURE (P)? 4

P = Pump Head

Hd = Height difference between the pump and the highest point of use

Hs = Pressure already available at the pump level (tank example with positive suction head). If you pump water under the level of the pump (well, river, underground tank), contact your Dealer in order to calculate the suction lift and to select the right pump

Hf = Friction loss or pipe resistance to water flow (see page 48)

Pr = Residual pressure, i.e. the required pressure at the tap, shower or sprinkler. As a guide, shower head, standard ½" tap or sprinkler requires approx. 150 kPa (15 m or 21 psi)

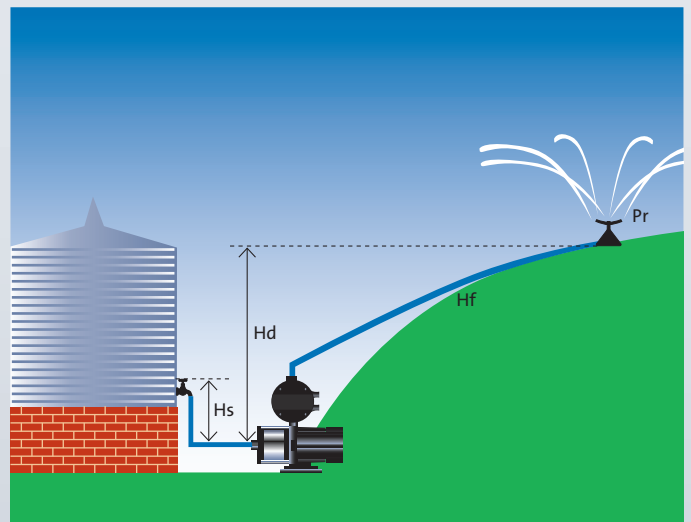

CALCULATE THE PRESSURE 5

$$P = (\quad) Hd - (\quad) Hs + (\quad) Hf + (\quad) Pr$$

Example

Q (Flow rate) = 60 L/min = 4 (sprinklers) x 15 L/min

Hs = 2 m

Hd = 15 m

Hf = 3.6 m

(50 m of 40 mm Poly Pipe - see Friction Loss Chart, page 48)

Pr = 15 m (150 kPa)

P = 15 - 2 + 3.6 + 15 = 31.6 m = 310 kPa = 44 psi

INDEX

PRODUCT PAGES

SCALA2	03 - 04
CME Booster	05 - 06
CM Booster Self-Priming	07 - 08
CM-PS	09 - 10
Pressure Manager	11 - 12
SQNE	13 - 14
SP A	15 - 16
UNILIFT KP	17 - 18
UNILIFT AP 12	19 - 20
UNILIFT AP 35 & 50	21 - 22
SOLOLIFT2	23 - 24
UPA	25
COMFORT PM	26
UPS (N)	27
ALPHA 2 (N)	28

SKIP TO PAGE 27 FOR

BasicLine
by **GRUNDFOS**

SCALA2



GRUNDFOS SCALA2 is a robust, composite, variable speed pump that adjusts performance according to water demand, providing constant pressure to all taps. The fully integrated pump includes a motor, tank, sensor, drive and non-return valve in one compact unit that is quick and easy to install. The SCALA2 is self-priming, allowing for use from both above and below ground water sources and the water-cooled motor ensures quiet operation.



FEATURES

Variable Speed

The pump adjusts performance according to water demand, providing constant pressure to all taps regardless of variations in demand or inlet pressure.

Self-Priming

Ideal for pressurising water from above or below ground water sources with a suction lift of up to 8 metres and self-priming up to 4 metres.

Energy Efficient

The pump features a permanent magnet motor to help reduce power consumption while the frequency controller matches the power consumption with the required water output, also helping to conserve energy and reduce energy bills.

Simple Selection

One model to suit most domestic applications makes selection easy.

User Friendly

The easy to use control panel features LED indicators displaying power status, pressure setting and alarm indicators lights.

Protective Functions

To protect the pump and help ensure a long life, a range of protective features are incorporated into the pump such as; dry-run protection, anti-cycling alarm, auto-reset and maximum continuous operation time (30 mins).

Easy Installation

Quick and easy installation in just three steps; connect the pipes, prime the pump and plug into the power outlet.

Integrated Non-Return Valve

No additional non-return valve required - plug and pump solution.

APPLICATIONS

- Mains boosting
- Household water supply
- Pressure boosting from above ground water tanks
- Pressure boosting from below ground water sources eg. Below ground tank/dam



PERFORMANCE

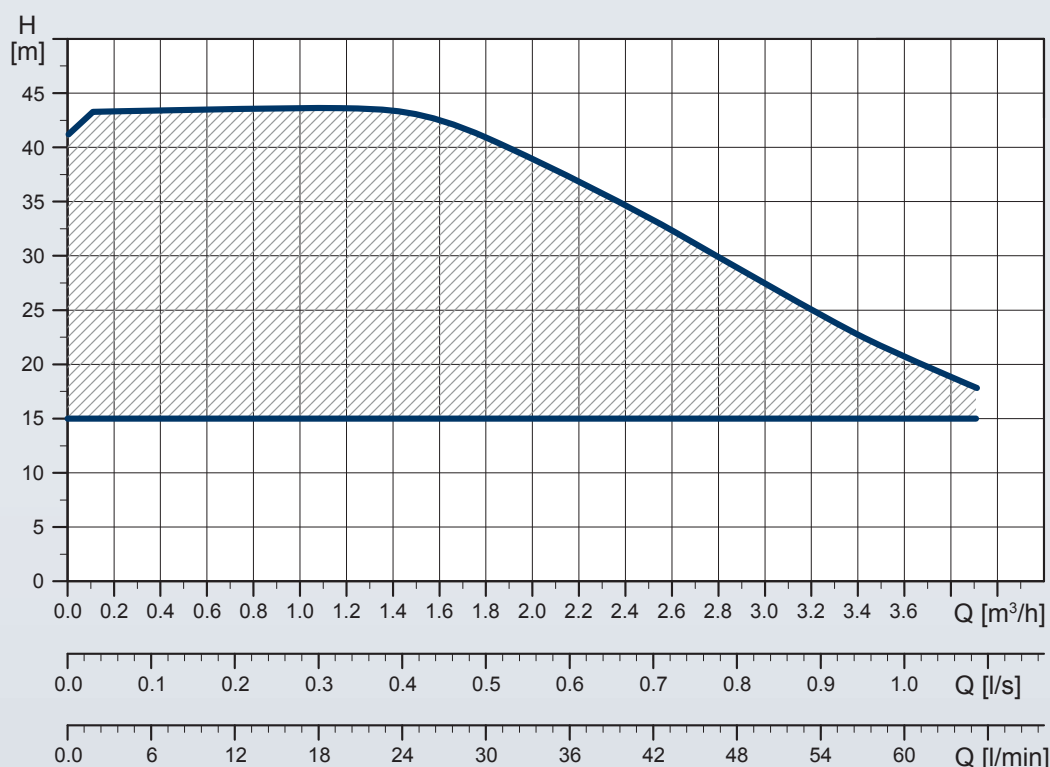

OPERATING CONDITIONS

System pressure

Max. 10 bar

Liquid temperature

0°C to +45°C

Ambient temperature

Max. 55°C

DIMENSIONS

TECHNICAL DATA

Mains voltage

1 x 240 V, 50 Hz

Enclosure class

F

Insulation class

X4D (suitable for outdoor installation)

Sound pressure level

<47 dBa

Approvals and markings

ASNZ4020, CE

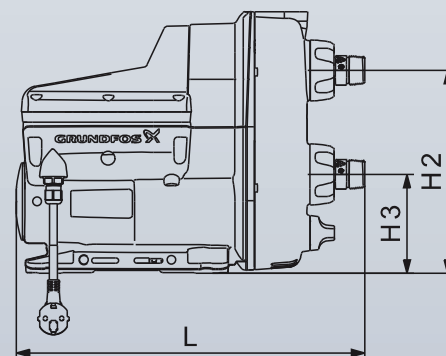
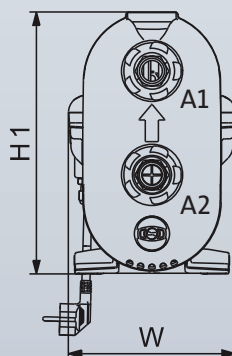

Model	Power Input (kW)	Dimensions (mm)							Weight (kg)
		H1	H2	H3	L	W	A1	A2	
SCALA2	0.55	302	234	114	403	193	1" F	1" F	10

CME Booster / CME TWIN Booster



A variable speed pump that adjust accordingly to water demand, resulting in lower running costs. All wetted components are constructed from high quality stainless steel ensuring, the water quality is not affected by pump materials. The pump will provide constant pressure at the tap (up to pump capacity), regardless of variation in demand or inlet pressure.

The CME TWIN Booster system consists of two CME Boosters connected in parallel and mounted on a common base plate.



FEATURES

Robust design

All wetted parts are made from high quality stainless steel to ensure the longest life possible.

Energy saving

The frequency controller of the CME Booster matches the power consumption with the required water output, helping to conserve energy.

Easy installation

The CME Booster is very easy to install. Once the booster has been connected to the pipework, it is simply a matter of putting the plug into a socket, and the system is operational.

Quiet operation

The CME Booster operates quietly, at around 55 decibels, significantly quieter than most pumps currently available on the market.

User-friendly interface

The user-friendly interface features LED indicators showing operational status and buttons for pressure adjustment.

Protective features

The CME Booster features dry run protection to automatically stop the pump if the water source runs out. The pump is also protected against any accidental overload by built-in thermal protection. These protective features help to ensure the longest life possible.

Cascade Control

CME TWIN Booster cascade control ensures that the performance automatically adapts to demand by switching pumps on or off and by changing the speed of the pumps in operation.

Automatic pump alternation

CME TWIN Booster automatically alternates the pumps so the operating demand of each pump is evenly distributed over time to help ensure a long life.

APPLICATIONS

- Mains boosting
- Household water supply
- Pressure boosting from above ground water tanks
- Light industrial use

TECHNICAL DATA

Mains voltage

1 x 240 V, 50 Hz

Enclosure class

IP55

Insulation class

F

Sound pressure level

< 55 dB

Approvals and markings

ASNZ4020, CE



CME Booster / CME TWIN Booster

PERFORMANCE

CME Booster

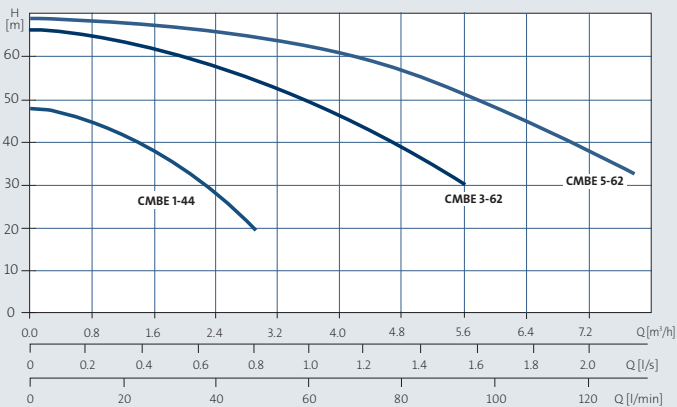

CME TWIN Booster

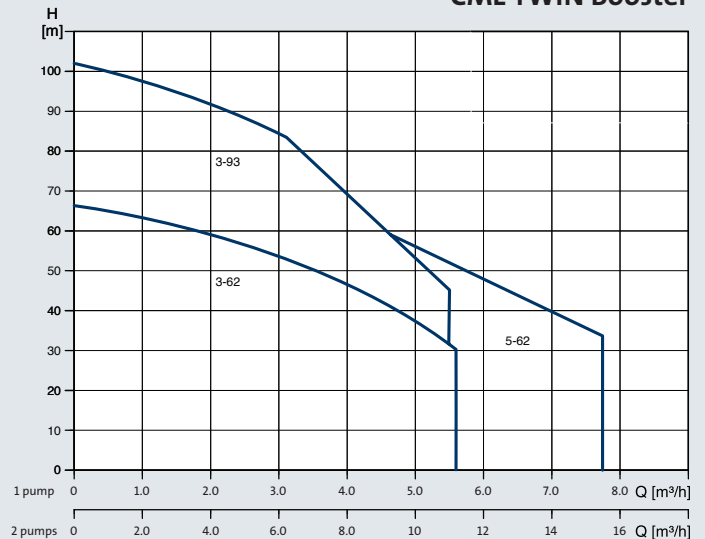

OPERATING CONDITIONS

System pressure

Max. 10 bar

Liquid temperature

0 °C to 60 °C

Ambient temperature

Max. 55 °C

Relative air humidity

Max. 95 %

DIMENSIONS

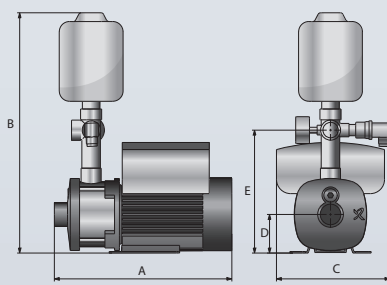

CME Booster

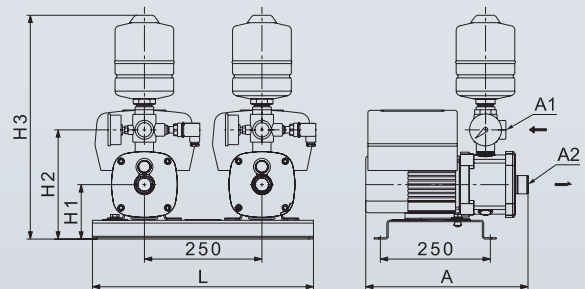

CME TWIN Booster

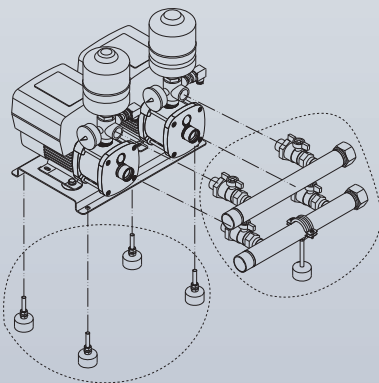

Suction & Discharge Manifold

Model	Power (kW)	Connections		Dimensions (mm)					Weight (kg)
		Outlet	Inlet	A	B	C	D	E	
CMBE 1-44	0.55	1" F	1" F	345	467	221	75	239	16.1
CMBE 3-62	1.1	1" F	1" F	345	467	221	75	239	17.4
CMBE 5-62	1.5	1" F	1¼" F	345	467	221	75	239	18.8

Model	Power (kW)	Connections		Dimensions (mm)					Weight (kg)
		Inlet	Outlet	H3	H2	H1	L	A	
CMBE TWIN 3-62	1.21	1" F	1" F	485	235	110	475	344	40kg
CMBE TWIN 3-93	1.72	1" F	1" F	495	250	125	475	404	44kg
CMBE TWIN 5-62	1.72	1" F	1¼" F	495	250	125	475	350	45kg

Old models		Suitable replacement models
CH-PC	CM Booster	CME Booster
CH2-40 PC	CMB 3-3	CMBE 1-44
CH4-50 PC	CMB 5-5	CMBE 3-62
CH4-60 PC		CMBE 5-62

Please Note: Conversion at 250 kPa

CM Booster Self-Priming



The Grundfos CM Booster Self-Priming is a compact booster pump designed for domestic and light industrial use. The booster unit consists of a robust multistage centrifugal pump and a generator friendly PM1 or PM2 Pressure Manager. The Pressure Manager allows the pump to start and stop automatically according to demand and protects the pump from dry running. The CM Booster Self-Priming is the perfect solution if you are struggling with insufficient mains pressure, and can also be used with above or below ground water sources.



FEATURES

Self-priming

With a suction lift of up to 8 metres (self-priming up to 4 metres), the CM Booster Self-Priming is ideal for pressurising water from above or below ground water sources.

Robust design

All wetted parts are made from high quality, corrosion resistant stainless steel to ensure the longest life possible.

User-friendly interface

The pump features a user-friendly interface with LED indicators displaying power status, pump running, alarm indication and pressure indication (excluding CMB-SP 1-36).

Protective features

The pump incorporates a range of protective features such as; dry run protection, thermal overload protection, cycling alarm and maximum continuous operation time - 30 mins (excluding CMB-SP 1-36) to protect the pump and ensure a long life.

Easy installation

The booster unit is a compact and adaptable solution, which makes it suitable for most installations. Simply connect the inlet and outlet and adjust the start pressure to suit individual requirements and you have a fully operational booster unit.

Integrated non-return valve

Non-return valve for backflow prevention.

APPLICATIONS

- Mains boosting
- Household water supply
- Boosting from above ground water tanks
- Boosting from below ground water sources e.g. below ground tank/dam
- Light industrial use



CM Booster Self-Priming

PERFORMANCE

CMB-SP 1 & CMB-SP 3

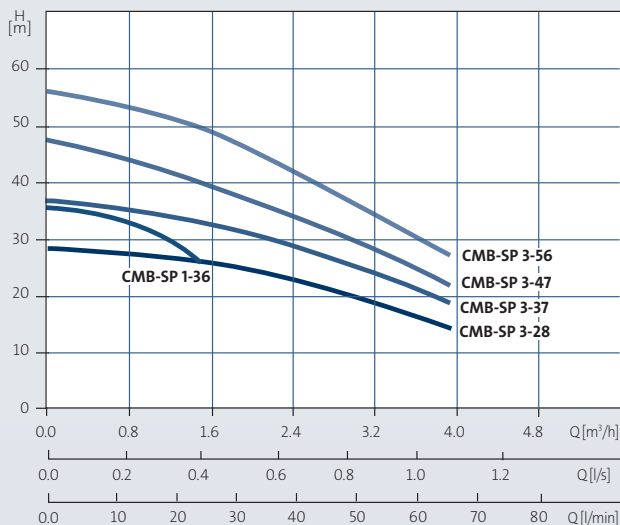

CMB-SP 5

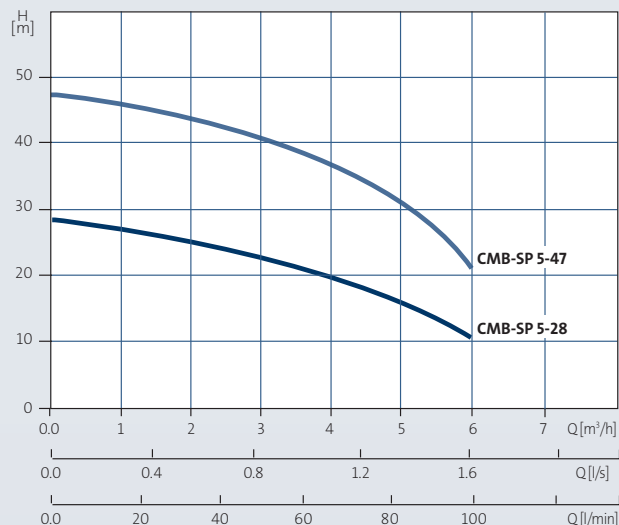

OPERATING CONDITIONS

System pressure

Max. 10 bar

Liquid temperature

0 °C to 60 °C

Ambient temperature

Max. 55 °C

Relative air humidity

Max. 95 %

DIMENSIONS

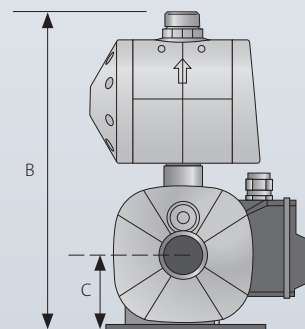
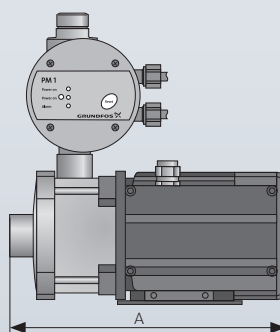

TECHNICAL DATA

Mains voltage

1 x 240 V, 50 Hz

Enclosure class

IP55

Insulation class

F

Sound pressure level

55 dB

Start/stop frequency

Max. 100 per hour

Approvals and markings

ASNZ4020, CE

Model	Power (kW)	Connections		Dimensions (mm)			Weight (kg)
		Outlet	Inlet	A	B	C	
CMB-SP 1-36	0.5	1" M	1" F	377	317	75	14.1
CMB-SP 3-28	0.5	1" M	1" F	377	317	75	13.7
CMB-SP 3-37	0.5	1" M	1" F	377	317	75	14.1
CMB-SP 3-47	0.5	1" M	1" F	413	317	75	14.4
CMB-SP 3-56	0.67	1" M	1" F	453	317	75	16.4
CMB-SP 5-28	0.5	1" M	1" F	377	317	75	13.7
CMB-SP 5-47	0.9	1" M	1" F	453	317	75	16.9

Old models		Suitable replacement models
CH-PC	CM Booster	CM Booster Self-Priming
CH2-30 PC	CMB 1-4	CMB-SP 1-36
CH2-40 PC	CMB 3-3	CMB-SP 3-28
CH2-50 PC	CMB 3-4	CMB-SP 3-37
CH2-60 PC	CMB 3-5	CMB-SP 3-47
	CMB 3-6	CMB-SP 3-56
CH4-40 PC	CMB 5-3	CMB-SP 5-28
CH4-50 PC	CMB 5-5	CMB-SP 5-47

CM-PS



The CM-PS is a compact booster solution designed for domestic and light industrial use. The booster unit consists of a robust CM pump, 5-way valve and a pressure switch. To complete the booster system a pressure tank must be fitted. The pressure switch and pressure tank ensure a convenient water supply with a minimum start/stop frequency.



FEATURES

Robust design

All wetted parts are made from high quality stainless steel including the impeller, pump housing and shaft to ensure the longest life possible.

Automatic operation

The built-in pressure switch automatically starts and stops the pump according to demand.

Easy installation

The booster unit is a compact solution, which makes it suitable for most installations. Simply connect your own pressure tank, inlet and outlet, and you have a fully operational booster unit.

Great system comfort

The diaphragm tank increases system comfort by limiting the switching frequency of the pump and compensating for pressure drops when a tap is opened. It also reduces problems with water hammer in the pipework.

Motor protection

The pump is effectively protected against any accidental overload, by built-in thermal and current protection. This means that no additional motor protection is required.

APPLICATIONS

- Mains boosting
- Boosting from above ground water tanks

Model	Connection size (mm)	Capacity (L)	Mounting type	Max pressure (kPa)
GT-H-18 PN10 G1 V	1" M	18	Pipe	1000
GT-H-18 PN16 G1 V	1" M	18	Pipe	1600
GT-H-60 PN10 G1 V	1" F	60	Free standing	1000
GT-H-80 PN10 G1 V	1" F	80	Free standing	1000
GT-H-80 PN16 G1 V	1" F	80	Free standing	1600
GT-H-100 PN10 G1 V	1" F	100	Free standing	1000
GT-D-130 PN10 G1 V	1" F	130	Free standing	1000
GT-D-200 PN10 G1 1/4 V	1 1/4" F	170	Free standing	1000
GT-D-240 PN10 G1 1/4 V	1 1/4" F	240	Free standing	1000
GT-D-300 PN10 G1 1/4 V	1 1/4" F	300	Free standing	1000
GT-D-450 PN10 G1 1/4 V	1 1/4" F	450	Free standing	1000

Note: Recommended tank size is dependant on application. To avoid rapid cycling Grundfos recommends the following tank sizes:

CM1 > 80 L

CM3 > 200 L

CM5 > 300 L

CM10 - 450 L

PERFORMANCE

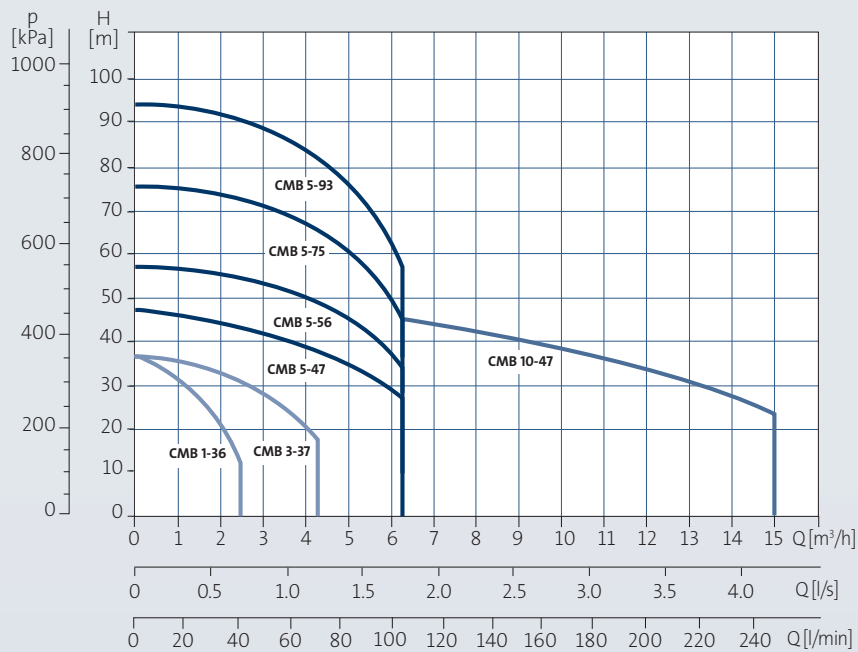

OPERATING CONDITIONS

System pressure

Max. 10 bar

Liquid temperature

0 °C to 60 °C

Ambient temperature

Max. 60 °C

Relative air humidity

Max. 95 %

DIMENSIONS

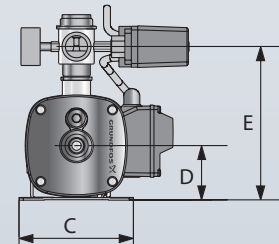
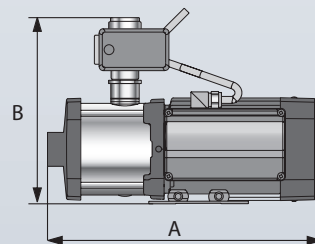

Model	Power (kW)	Connections		Dimensions (mm)					Weight (kg)
		Outlet	Inlet	A	B	C	D	E	
CMB 1-36	0.5	1" F	1" F	323	255	158	75	208	18.0
CMB 3-37	0.5	1" F	1" F	323	255	158	75	208	18.0
CMB 5-47	0.9	1" F	1¼" F	381	255	158	75	208	20.7
CMB 5-56	1.3	1" F	1¼" F	466.5	270	178	90	223	27.6
CMB 5-75	1.3	1" F	1¼" F	502.5	270	178	90	223	30.0
CMB 5-93	1.9	1" F	1¼" F	538.5	270	178	90	223	31.0
CMB 10-47	1.9	1½" F	1½" F	450	323	199	100	261	33.5

TECHNICAL DATA

Mains voltage

1 x 240 V, 50 Hz

Enclosure class

IP55

Insulation class

F

Sound pressure level

50-60 dB

Start/stop frequency

Max. 100 per hour

Approvals and markings

ASNZ4020, CE

Pressure Manager



The all-in-one Grundfos Pressure Manager is an intelligent waterworks that controls your pump in accordance with consumption in domestic water supply and booster systems. The Pressure Manager is suitable for toilets, washing machines and outside taps. This state-of-the-art product offers benefits from innovative Grundfos features including functionality, system integration, plug-and-pump convenience and ease of use. The Pressure Manager offers a choice of two excellent models: the PM1 for basic flexibility, and the PM2 for all-round control.



FEATURES

Internal pressure tank

The Pressure Manager incorporates a small internal pressure tank which minimises the number of starts and stops of the pump in case of minor leakages.

Free position installation

The Pressure Manager can freely be installed vertically, horizontally or at an angle, if you struggle with confined spaces. Furthermore, the display can be turned 360 degrees, so it is always readable.

Integrated non-return valve

Non-return valve for backflow prevention.



PM 1 - Basic flexibility

The PM1 is suitable for applications where there is a need to start and stop the pump according to consumption. It is the basic flexibility solution, offering pump start at 1.5 or 2.2 bar. The PM1 will start the pump when the starting pressure is reached and it will keep running as long as there is flow. It provides dry-running protection and a cycling alarm for increased safety. In addition, it is suitable for use on generators.

PM 2 - All-round control

The PM2 is the all-round control solution, offering adjustable pump start at 1.5 to 5 bar. This enables customisation to different types of installation and desired comfort levels. The start pressure is set inside the unit, whereas current pressure is read on the intuitive LED display on the front of the Pressure Manager. The PM2 starts the pump when the starting pressure is reached and keeps running as long as there is flow. It is equipped with an internal pressure tank to minimise starts and stops in the event of leakage in the installation. In addition, the PM2 can be optimised for operation with a large external pressure tank by enabling the 1-bar differential pressure function. This significantly reduces the number of operating hours of the pump in installations with a pressure tank. The PM2 is also suitable for use on generators.

Pressure Manager

PRESSURE LOSS

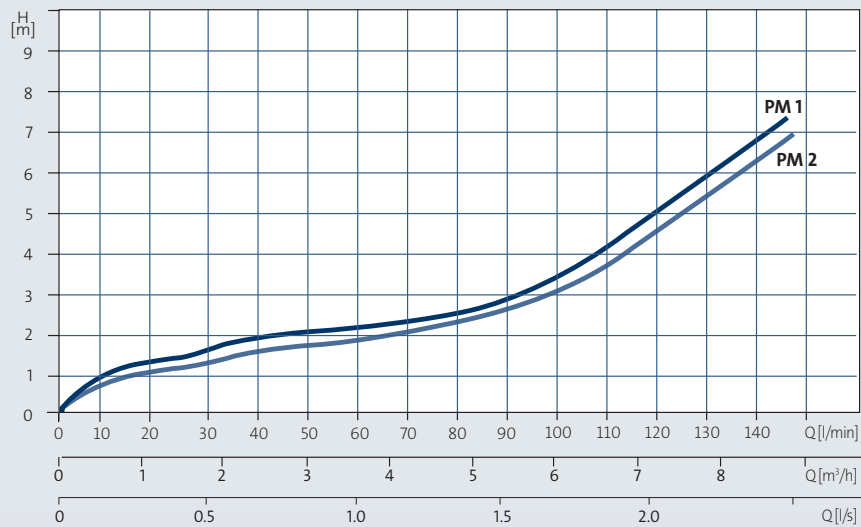

OPERATING CONDITIONS

Max. operating pressure

10 bar

Minimum flow

1.0 L/min

Liquid temperature

Max 60 °C

Ambient temperature

Max. 45 °C

Maximum humidity

95 % RH

DIMENSIONS

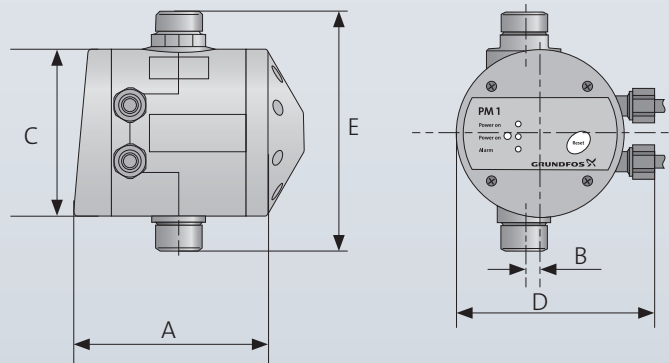

TECHNICAL DATA

Mains voltage

1 x 240 VAC, 50 Hz

Enclosure class

IP65

Sound pressure level

at 0-4 m³/h 26 dB

Volume of internal pressure tank

0.1 L

Approvals and markings

VDE, CB, C-tick, CE, GOST, RoHS, WRAS, ACS

Model	Max Current (A)	Connections		Dimensions (mm)					Q/min (Lpm)	P Start (kPa)
		Outlet	Inlet	A	B	C	D	E		
PM 1-15	6	1" M	1" M	165	12	120	143	171	1 Lpm	150
PM 1-22	6	1" M	1" M	165	12	120	143	171	1 Lpm	220
PM2	10	1" M	1" M	175	12	120	143	171	1 Lpm	150-500



SQNE is a small and compact submersible multi-stage pump designed for constant pressure operation in domestic applications. The motor of the SQNE pump is a permanent magnet motor with a micro frequency converter ensuring optimum efficiency. The built-in frequency converter features protective functions and soft-starting, which reduces starting current and gives smooth and steady acceleration and dry running protection. The SQNE pump is handy and user-friendly due to its low weight and 3-inch diameter. For constant pressure operation, the SQE coupled the CU300 or CU301 control unit is required



FEATURES

Constant pressure operation

Using a CU300/301 with the SQNE your water pressure will always remain constant pressure regardless of how many family members are consuming water. As more taps are opened, the pump automatically increases its speed, maintaining your chosen pressure at any flow rate. Greater comfort is added to your life and greater value added to your home.

Excellent starting capabilities

The soft starter minimises the risk of wear on the pump and prevents overloading of the mains during start-up. Its soft-start system also reduces water hammering, light flickering and other electrical disturbances.

Overvoltage and undervoltage protection

The integrated protection prevents damage to the motor in case the supply voltage moves outside the permissible voltage range.

Overload protection

The SQNE eliminates the need for motor protection. If the pump is exposed to heavy load the motor will automatically reduce its speed, or if the pump is blocked it automatically stops pumping.

Over-heating protection

As an extra protection, the electronic unit has a built-in temperature sensor. When the temperature exceeds a critical limit, the pump is stopped and when the temperature has dropped, the pump automatically starts.

Protection against upthrust

The SQNE is fitted with an upthrust bearing protecting both pump and motor against upthrust, thus preventing breakdown during the critical start-up phase.

OPERATING CONDITIONS

pH values

5 to 8

Liquid temperature

0 °C to 35 °C

TECHNICAL DATA

Mains voltage

1 x 240 V, 50 Hz

Enclosure class

IP68

Insulation class

F

Installation depth

Max. 150 m below static water level

Pump diameter

74 mm

Borehole diameter

Min. 76 mm

Approvals and markings

CE, UL, cUL

PERFORMANCE

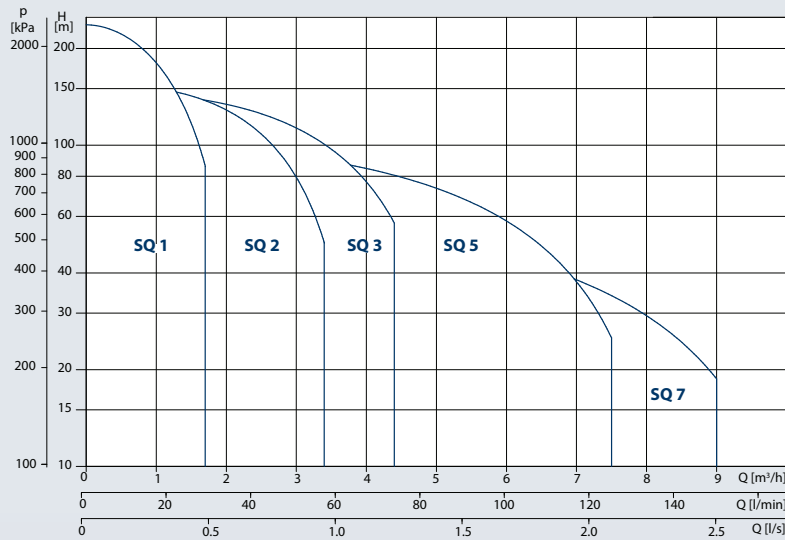

DIMENSIONS

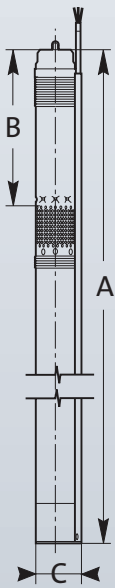

Model	Power-P2 (kW)	Max Current (A)	Outlet	Dimensions (mm)			Weight (kg)
				A	B	C	
SQE 1-35 N	0.7	2.5	1 ¼"	741	265	74	4.7
SQE 1-50 N	0.7	3.3	1 ¼"	741	265	74	4.8
SQE 1-65 N	0.7	4.3	1 ¼"	768	592	74	4.9
SQE 1-80 N	1.15	5.1	1 ¼"	825	346	74	5.6
SQE 1-95 N	1.15	6.0	1 ¼"	825	346	74	5.6
SQE 1-110 N	1.15	7.0	1 ¼"	852	373	74	5.7
SQE 1-125 N	1.68	7.8	1 ¼"	942	427	74	6.4
SQE 1-140 N	1.68	8.6	1 ¼"	942	427	74	6.5
SQE 1-155 N	1.85	9.6	1 ¼"	969	454	74	6.7
SQE 2-35 N	0.7	3.0	1 ¼"	741	265	74	4.7
SQE 2-55 N	0.7	4.3	1 ¼"	741	265	74	4.8
SQE 2-70 N	1.15	5.5	1 ¼"	768	292	74	5.4
SQE 2-85 N	1.15	6.8	1 ¼"	825	346	74	5.5
SQE 2-100 N	1.68	8.0	1 ¼"	861	346	74	6.2
SQE 2-115 N	1.85	9.3	1 ¼"	888	373	74	6.3
SQE 3-30 N	0.7	3.0	1 ¼"	741	265	74	4.8
SQE 3-40 N	0.7	4.2	1 ¼"	741	265	74	4.8
SQE 3-55 N	1.15	5.4	1 ¼"	768	292	74	5.4
SQE 3-65 N	1.15	6.7	1 ¼"	825	346	74	6.1
SQE 3-80 N	1.68	7.8	1 ¼"	861	346	74	6.3
SQE 3-95 N	1.68	9.0	1 ¼"	888	373	74	6.4
SQE 3-105 N	1.85	10.3	1 ¼"	942	427	74	6.5
SQE 5-15 N	0.7	2.3	1 ½"	743	265	74	4.7
SQE 5-25 N	0.7	3.9	1 ½"	743	265	74	4.8
SQE 5-35 N	1.15	5.6	1 ½"	824	346	74	5.5
SQE 5-50 N	1.68	7.3	1 ½"	260	346	74	6.1
SQE 5-60 N	1.68	8.9	1 ½"	941	427	74	6.4
SQE 5-70 N	1.85	10.7	1 ½"	941	427	74	6.4
SQE 7-15 N	0.7	3.1	1 ½"	743	265	74	4.7
SQE 7-30 N	1.15	5.5	1 ½"	743	265	74	5.2
SQE 7-40 N	1.68	7.8	1 ½"	860	346	74	6.1

SP A

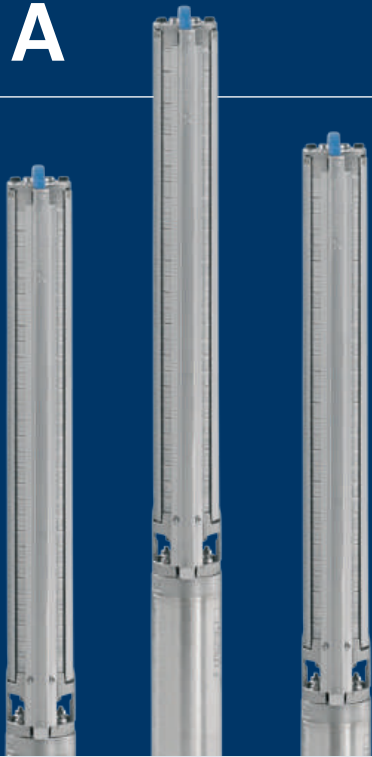

The Grundfos SP A is a 4-inch multi-stage, submersible pump designed for operation in boreholes. SP A is made entirely of corrosion-resistant stainless steel, offering high operating reliability regardless of the application.

The SP A offers high efficiency along with great resistance to sand and other abrasive particles.



FEATURES

100% high-grade stainless steel inside and outside

As standard, all Grundfos SP A pumps are made entirely of stainless steel DIN 1.4301 (AISI 304). Where particularly aggressive liquids are encountered, the SP pumps are available in extra high grade stainless steel DIN 1.4401 (AISI 316), or, for severe conditions, DIN 1.4539 (AISI 904 L) providing maximum reliability.

Bearings with sand channels

All bearings are water-lubricated and have a squared shape, enabling sand particles, if any, to leave the pump together with the pumped liquid.

Inlet strainer

The pump is mounted with an inlet strainer preventing particles over a certain size from entering the pump.

Non-return valve

SP A pumps have a built-in non-return valve preventing backflow in connection with pump stoppage.

Motor burnout protection

Protecting the motor against high motor temperatures is the simplest and cheapest way of avoiding a reduced motor life. The SP A motor is available with built-in temperature sensor and when used with the MP204 will monitor and protect against overheating.

Optional monitoring and controlling

A complete monitoring and control system is available for constant optimisation of the pumping system.

OPERATING CONDITIONS

Liquid temperature

0 °C to 30 °C at 0.15 m/s

Higher flow past motor equals higher permissible liquid temperature. Consult Grundfos for further information.

TECHNICAL DATA

Mains voltage

1 x 240 V, 50 Hz
3 x 415 V, 50Hz

Enclosure class

IP68

Insulation class

F

Installation depth

Max. 600 m

Approvals and markings

UL, CSA, VDE, CE

PERFORMANCE

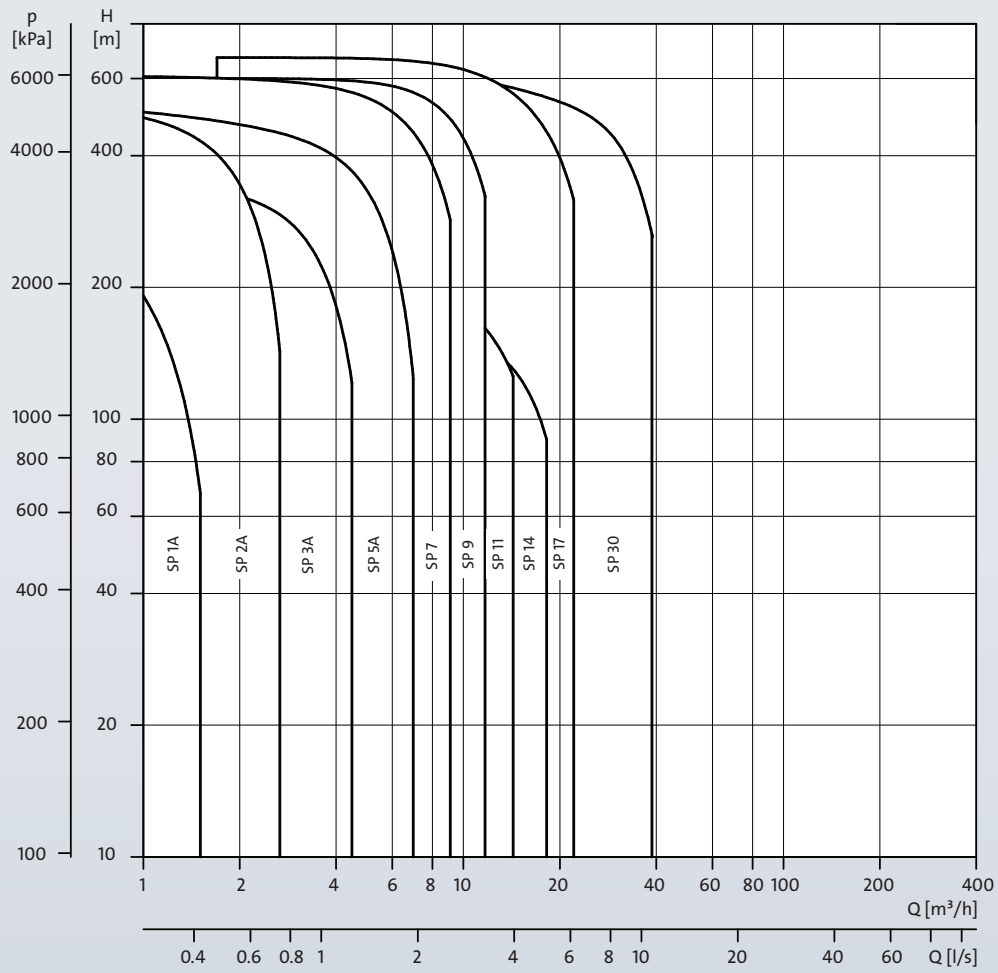

UNILIFT KP



The UNILIFT KP is a lightweight, single-stage pump with a semi-open impeller. They are designed for liquid transfer and pumping of drain water and grey wastewater containing particles up to a size of Ø10. All UNILIFT KP pumps are mostly made of stainless steel, with a stainless steel sleeve for cooling during operation. The pumps are small and handy, suitable for permanent installation or as a portable pump. The suction strainer at the bottom of the pump prevents particles larger than the pump is designed for from entering. The suction strainer is clipped on to the pump housing for easy removal, in case of maintenance.

All UNILIFT KP pumps can be supplied with or without float switch, for automatic or manual operation.



FEATURES

Lightweight and robust

The KP is a lightweight pump designed specifically for drainage jobs. Its stainless steel surface makes it robust, durable and corrosion free, which reduces maintenance to an absolute minimum.

Wet runner

The pump is designed with a canned rotor, which hermetically seals the rotor from the stator. This eliminates the need for a shaft seal, making the pump highly reliable and service friendly.

Prevention of backflow

An optional non-return flap valve can be fitted in the outlet in order to prevent backflow when the pump stops operating.

Thermal overload protection

The single-phase version is effectively protected against any accidental overload, by built-in thermal protection. This means that no additional motor protection is required.

Auto-restart

In case the motor cuts out due to thermal overload, the motor automatically starts again when it has cooled to normal temperature.

Handy and easily transportable

The carry handle mounted on the pump housing makes it handy and easily transportable.

Option for automatic operation

The pumps are available with float switches for automatic on/off operation between two liquid levels or with vertical float for operation in confined areas.

APPLICATIONS

- Domestic wastewater



PERFORMANCE

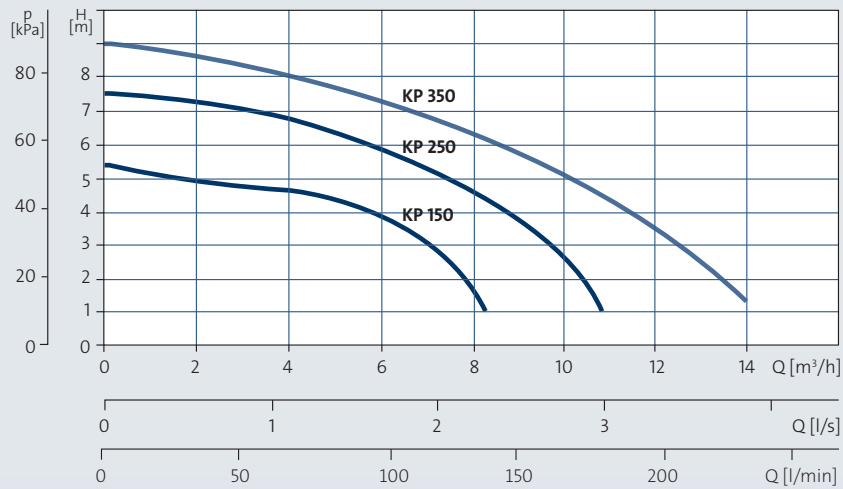

OPERATING CONDITIONS

Liquid temperature

0 °C to 50 °C

Max. particle size

Ø10 mm

pH concentration

4 to 9

Max. installation depth

10 m

TECHNICAL DATA

Mains voltage

1 x 240 V, 50 Hz

Enclosure class

IP68

Insulation class

F

Cable type

H07RN-F

Approvals and markings

CE, LGA, VDE, GS, EMV, GOST, UL, CSA and C-tick

DIMENSIONS

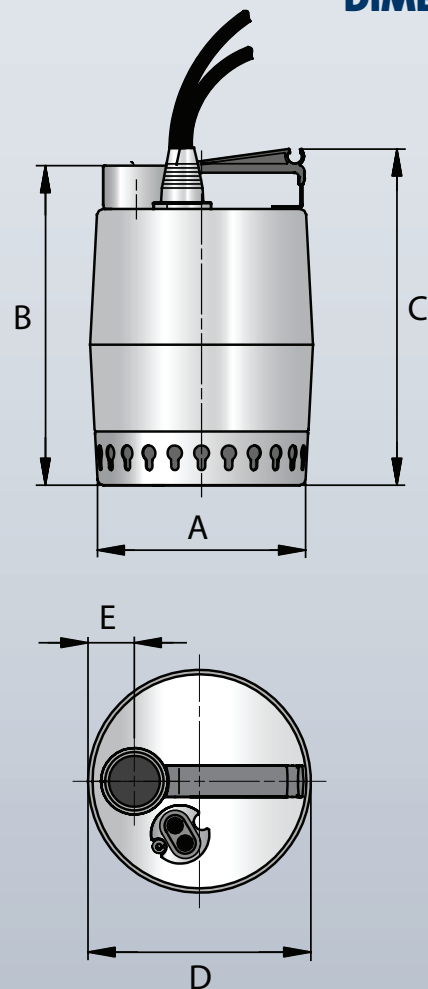

Model	Cable length (m)	Power - P2 (kW)	Connection size	Dimensions (mm)					Weight (kg)
				A	B	C	D	E	
UNILIFT KP 150	5	0.14	1¼" F	140	220	226	148	30	6.3
UNILIFT KP 250	5	0.25	1¼" F	140	220	226	148	30	6.6
UNILIFT KP 350	5	0.35	1¼" F	140	220	226	148	30	7.2

UNILIFT AP 12



The UNILIFT AP 12 is a single-stage, submersible pump with semi-open impeller, designed for pumping drainage water containing particles up to a size of up to 12 mm. UNILIFT AP12 is for automatic as well as manual operation and can be used in a permanent installation or as a portable pump. The pump is easily installed as it's fitted with a carry handle and 10 m mains cable. UNILIFT AP12 is mostly made of stainless steel, with a stainless steel sleeve for cooling during operation. The stainless steel pump sleeve is made in one piece with a clipped on suction strainer for easy removal in case of maintenance.



FEATURES

Robust design

The materials of the pump ensure excellent corrosion resistance. The pump housing and impeller are made of high quality stainless steel. Furthermore, the mechanical shaft seal offers high-wear resistance and a long operating life.

Thermal overload protection

The single-phase version is effectively protected against any accidental overload by built-in thermal protection. This means that no additional motor protection is required.

Handy and easily transportable

The carry handle mounted on the pump housing makes it handy and easily transportable.

Option for automatic operation

The pumps are available with float switches for automatic on/off operation.

APPLICATIONS

- Domestic wastewater

TECHNICAL DATA

Mains voltage

1 x 240 V, 50 Hz

3 x 415 V, 50 Hz

Enclosure class

IP68

Insulation class

F

Cable type

H07RN-F

Approvals and markings

VDE, LGE, UL and CSA

PERFORMANCE

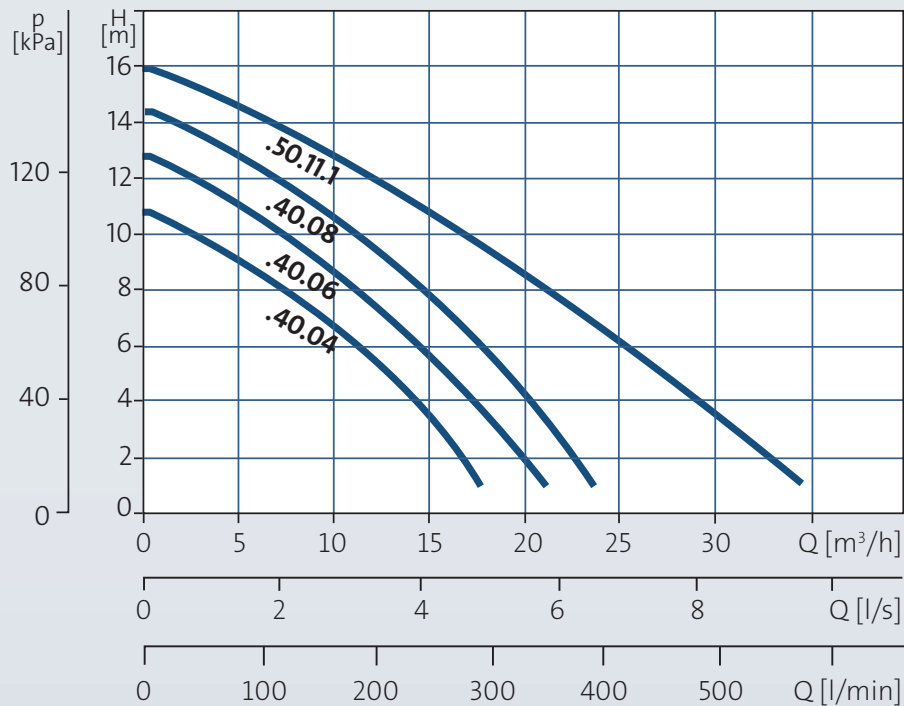

OPERATING CONDITIONS

Liquid temperature

0 °C to 55 °C

Max. particle size

Ø12 mm

pH concentration

4 to 10

Max. installation depth

10 m

DIMENSIONS

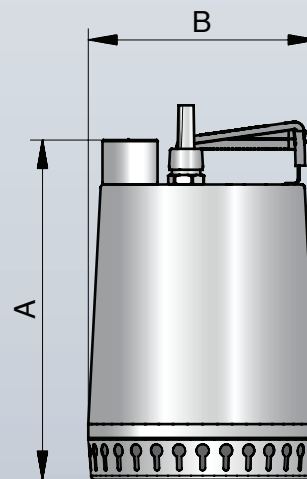

Model	Cable length (m)	Power - P2 (kW)	Connection size	Dimensions (mm)		Weight (kg)
				A	B	
UNILIFT AP12.40.04	10	0.4	1½" F	321	216	11
UNILIFT AP12.40.06	10	0.6	1½" F	321	216	11
UNILIFT AP12.40.08	10	0.8	1½" F	346	216	12.6
UNILIFT AP12.50.11	10	1.1	2" F	357	241	15.1

UNILIFT AP 35 & 50



The BasicLine by Grundfos UNILIFT AP 35 & 50 is a single-stage, submersible pump with vortex impeller, designed for pumping effluent and sewage, containing particles up to a size of Ø50 mm (Unilift AP 50) and Ø35 mm (Unilift AP 35) depending on the pump size. UNILIFT AP 35 & 50 is available for automatic as well as manual operation and can be used in a permanent installation or as a portable pump. The pump is easily installed, as it is fitted with a carry handle and 10m mains cable. UNILIFT AP 35 & 50 is mostly made of stainless steel, with a stainless steel sleeve for cooling during operation. The stainless steel pump sleeve is made in one piece, with a clipped on suction strainer, for easy removal, in case of maintenance.



FEATURES

Robust design

The materials of the pump ensure excellent corrosion resistance. The pump housing and impeller are made of high quality stainless steel. Furthermore, the mechanical shaft seal offers high-wear resistance and a long operating life.

Thermal overload protection

The single-phase version is effectively protected against any accidental overload, by built-in thermal protection. This means that no additional motor protection is required.

Handy and easily transportable

The carry handle mounted on the pump housing makes it handy and easily transportable.

Option for automatic operation

The pumps are available with float switches for automatic on/off operation.

OPERATING CONDITIONS

Liquid temperature

0 °C to 55 °C

Max. particle size

AP 35 - Ø35 mm

AP 50 - Ø50 mm

pH concentration

4 to 10

Max. installation depth

10 m

TECHNICAL DATA

Mains voltage

1 x 240 V, 50 Hz

Enclosure class

IP68

Insulation class

F

Cable type

H07RN-F

Approvals and markings

VDE, LGE, UL and CSA

UNILIFT AP 35 & 50

PERFORMANCE

AP 35

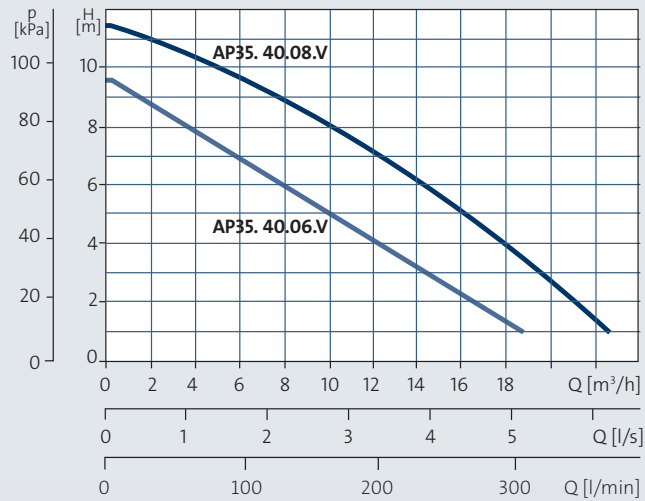

AP 50

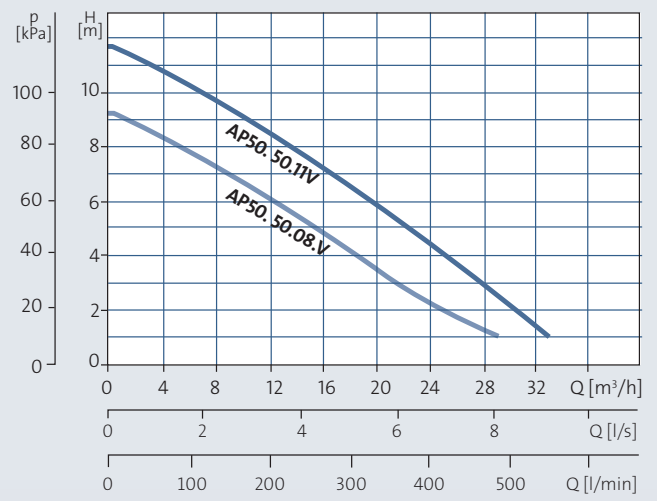

DIMENSIONS

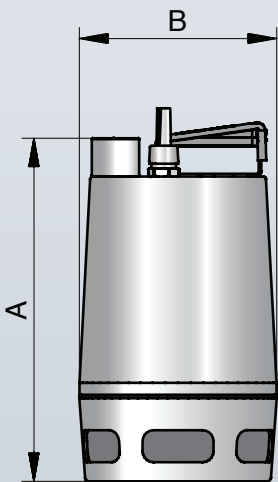

Model	Cable length (m)	Power - P2 (kW)	Connection size	Dimensions (mm)		Weight (kg)
				A	B	
UNILIFT AP35.40.06	10	0.6	1½" F	376	216	11.4
UNILIFT AP35.40.08	10	0.8	1½" F	410	216	12.7
UNILIFT AP50.50.08	10	0.8	2" F	436	241	15.1
UNILIFT AP50.50.11	10	1.1	2" F	436	241	15.1

SOLOLIFT2

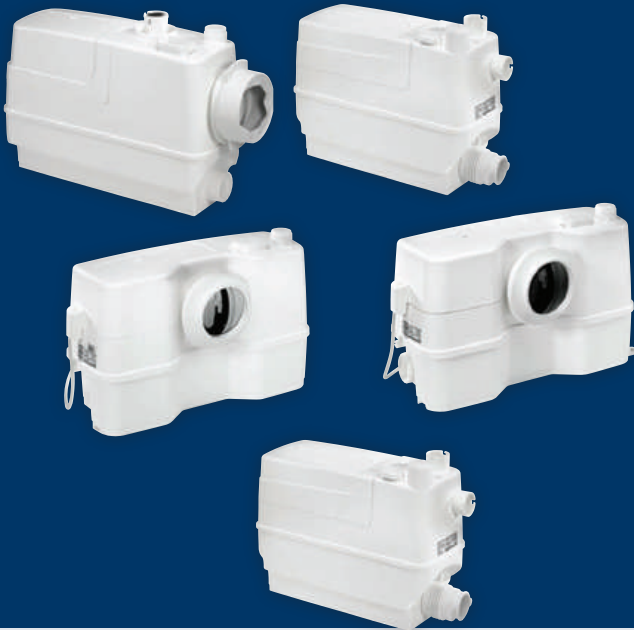

SOLOLIFT2 lifting stations are practical, compact and ready to install solution for discharging domestic effluent that cannot reach the main sewage pipe directly. They have the ability to grind and evacuate sewage and wastewater quickly and efficiently. They offer the ideal solution for the renovation and modernisation of existing buildings, where the location may be remote from the main soil pipe without the need for costly pipe installations. SOLOLIFT2s are able to be installed where a natural slope cannot be installed in a shower or toilet. Further, they are available in wall hung and freestanding models which cater to every space.



FEATURES

- The most powerful, reliable and service friendly lifting station on the market
- Unique, welded, pressure tight tank
- Smart adjustable inlet connectors allow movement of up to 10 mm - easy installation and replacement
- Captive screw fastening, external pressure switch and tank draining enable fast and clean repairs and service

TECHNICAL DATA

- Maximum liquid temperature: 50°C (90°C SOLOLIFT2 C-3 (30 min))
- Unique, welded, pressure tight tank to ensure safety and reliability particularly in high pressure grey water applications
- Smart adjustable inlet connectors allow movement of up to 10 mm, both vertically and horizontally for easy fitting to existing pipes
- 1.2 metre cable with plug

DIMENSIONS

Model	Power (Watts)	Dimensions (mm)		Weight (kg)
		H	L	
SOLOLIFT WC-1	620	347	453	7.2
SOLOLIFT WC-3	620	347	453	7.5
SOLOLIFT CWC-3	620	368	495	7
SOLOLIFT C-3	640	255	373	6.5
SOLOLIFT D-2	280	147	147	4.2

APPLICATIONS

- Discharging domestic effluent that cannot reach the main sewage pipe directly
- Grind and evacuate sewage and wastewater (WC versions)

TECHNICAL DATA

SOLOLIFT2 C-3 for washing machines, dishwasher, kitchen sink, bathtub, shower and washbasin

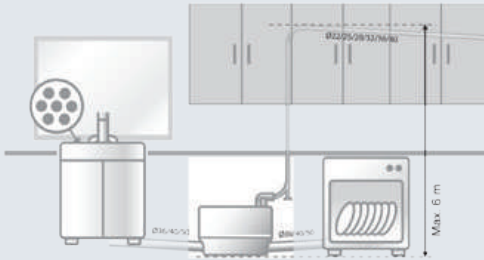

SOLOLIFT2 D-2 for shower and wash basin

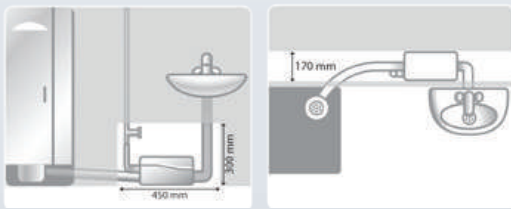

SOLOLIFT2 WC-1 for single toilet and washbasin

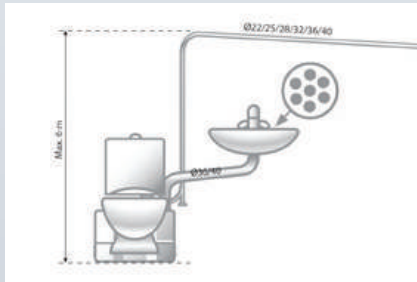

SOLOLIFT2 WC-3 for toilet, washbasin, bidet and a shower

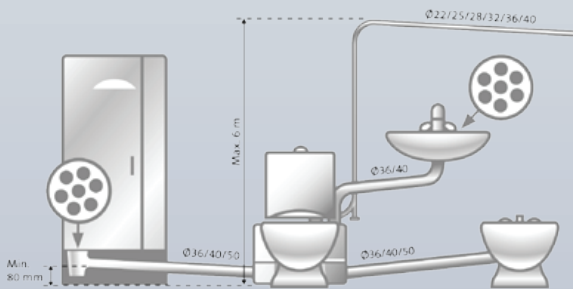

SOLOLIFT2 CWC-3 for wall-hung toilet, washbasin, bidet and a shower

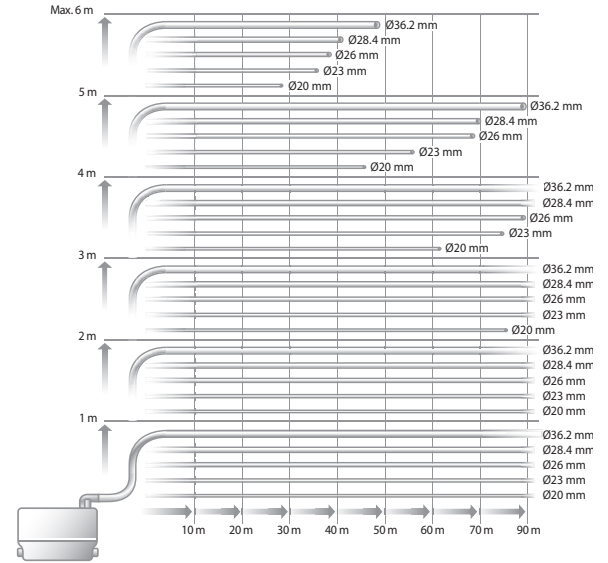
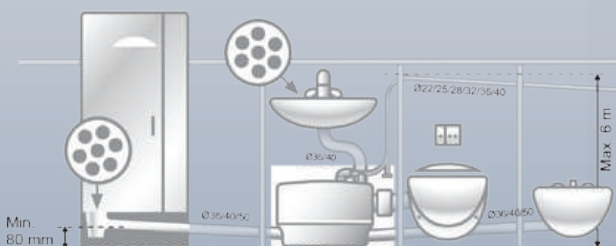

SOLOLIFT2 C-3

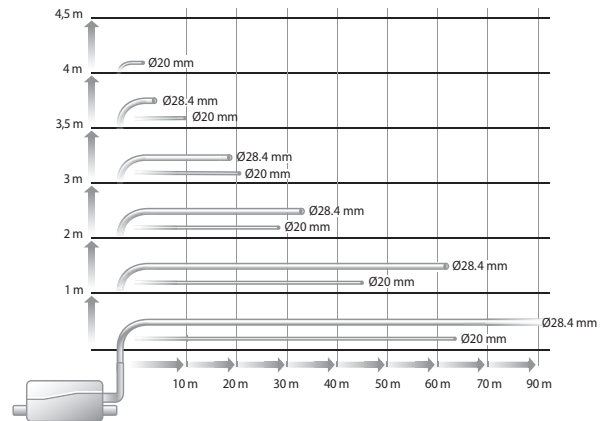

SOLOLIFT2 D-2

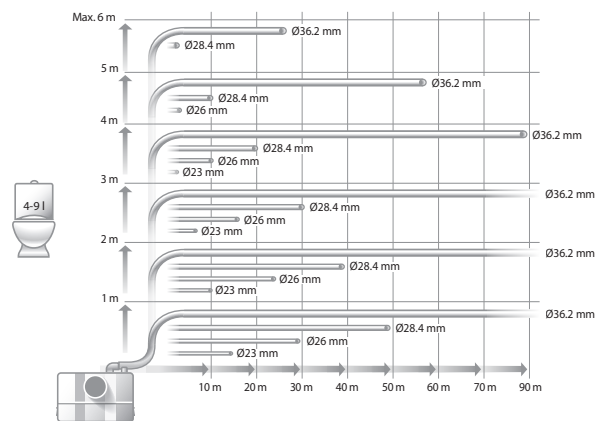



The UPA Homebooster is a circulator pump designed for pressure boosting hot water systems. The pump provides additional pressure to showers, taps and similar outlet points. The UPA Homebooster is for use in open systems. The pump incorporates a flow switch which starts or stops the pump when a tap is turned on or off.

FEATURES

Increased comfort

Typically boosting 50 to 75kPa to the existing inlet pressure ensure a steady firm pressure, perfect to boost hot water pressure throughout the home.

Robust design

The pump is made of materials that ensure excellent corrosion resistance. Designed for open systems UPA is constructed from quality stainless steel with a high grade composite impeller.

Quiet operation

Whisper quiet operation makes the UPA Homebooster suitable to be unobtrusively installed in the roof space.

Automatic operation

Built in flow sensor automatically starting with water flow.

PERFORMANCE

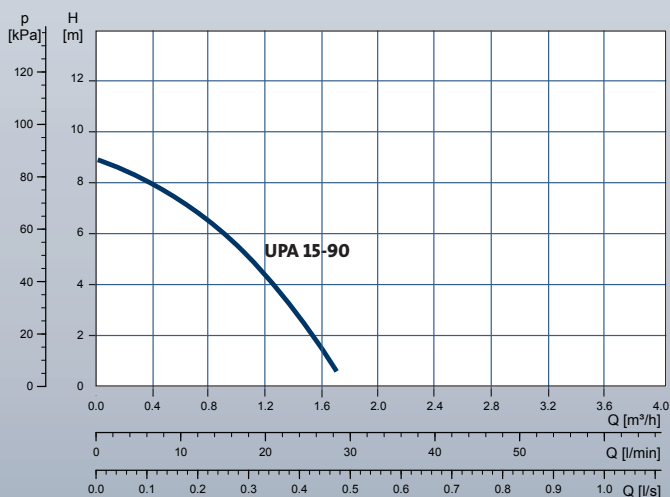

APPLICATIONS

- Domestic hot water circulation



OPERATING CONDITIONS

System pressure

6 bar

Liquid temperature

2 - 95 degrees

Ambient temperature

40 °C

Relative air humidity

95 %

TECHNICAL DATA

Mains voltage

1 x 240 V, 50 Hz

Enclosure class

IP42

Insulation class

H

COMFORT PM



UP 15-14BA PM

The COMFORT range is designed for re-circulation of domestic hot water in one family houses. The COMFORT PM range is the high efficiency choice with an energy usage of only 8 W. The intelligent COMFORT AUTOADAPT PM automatically adapts to the individual hot water consumption pattern in the household and only runs when hot water is needed.

FEATURES

Quiet operation

The low noise permanent magnet motor, at <43dBa the Comfort PM is ultra-quiet.

Reduce wastewater

All COMFORT pumps - with or without the autoadapt function - combined with a return pipe deliver instantly hot water all over the house. This eliminates the expensive and annoying wait for the water to get warm and reduces the annual consumption of domestic water. The results are lower costs while still ensuring the comfort of instant hot water.

Robust design

The pump is made of materials that ensure excellent corrosion resistance. Designed for open systems Comfort PM is constructed from quality brass housing with a high grade composite impeller.

AUTOADAPT

The AUTOADAPT version learns the user pattern of the customer and learns from it. It only runs when hot water is needed.

PERFORMANCE

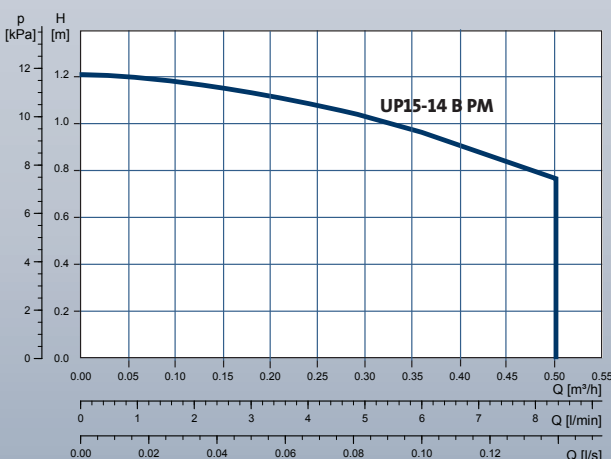

APPLICATIONS

- Domestic hot water circulation



OPERATING CONDITIONS

System pressure

10 bar

Liquid temperature

2 to 110 °C

Ambient temperature

40 °C

Relative air humidity

95 %

TECHNICAL DATA

Mains voltage

1 x 240 V, 50 Hz

Enclosure class

IP44

Insulation class

F

Sound pressure level

43 dB

Approvals and markings

AS4020

DIMENSIONS

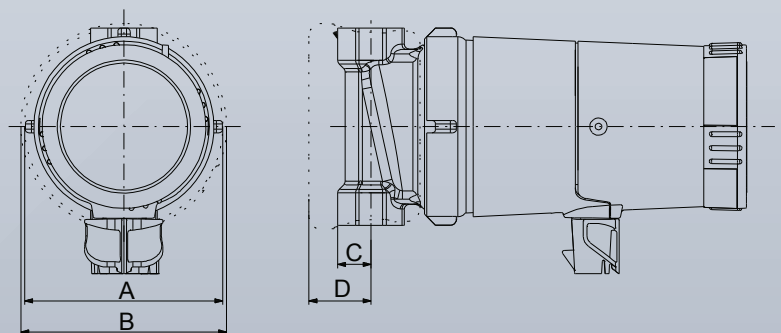

Model	Connection size	Dimensions (mm)				Weight (kg)
		A	B	C	D	
UP15-14B PM	½" F	84	13.5	133	80	1

UPS(N)



Grundfos UPS(N) pumps are the ideal choice for a wide range of domestic and commercial applications. The UPS(N) pumps are 3-speed wet rotor circulators and come in a wide range of materials and sizes. They feature an integrated pump and motor design ensuring greater ease of installation and durability. Maintenance free and whisper-quiet, these pumps are ideal for a variety of domestic and commercial heating and cooling systems.



FEATURES

Energy efficient

A speed switch on the motor allows the pump to be adjusted to the needs of the application, improving pump efficiency and reducing energy consumption.

Robust design

The pump is made of materials that ensure excellent corrosion resistance. Designed for open systems UPS(N) is constructed from quality stainless steel with a high grade composite impeller. The UPS is constructed from rugged cast iron and is the perfect choice for closed systems.

Quiet operation

Canned motor provides an operating noise level at less than 43 decibels, the UPS is extremely quiet.

Easy installation

The UPS is a compact, inline circulator pump, making it suitable for most installations.

OPERATING CONDITIONS

System pressure

10 bar

Liquid temperature

2 to 110 °C

Ambient temperature

40 °C

Relative air humidity

95 %

TECHNICAL DATA

Mains voltage

1 x 240 V, 50 Hz

Enclosure class

IP44

Insulation class

F

Sound pressure level

43 dB

Approvals and markings

UPS(N) AS4020

APPLICATIONS

- Circulating hot or cold water in open or closed systems.

PERFORMANCE

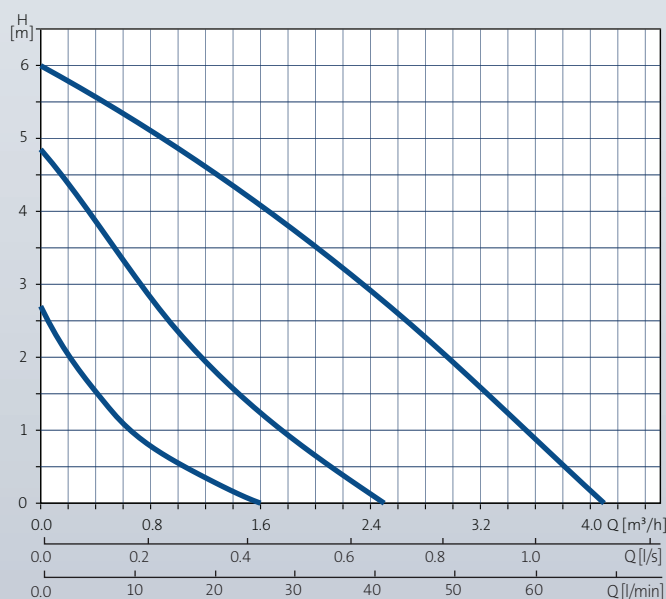

DIMENSIONS

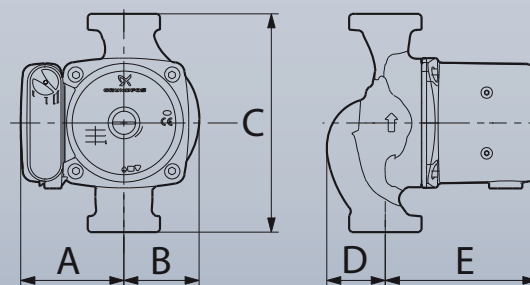

Model	Connection size	Dimensions (mm)					Weight (kg)
		A	B	C	D	E	
UPS20-60N	¾" F	75	51	150	28	102	2.8

ALPHA 2(N)



A typical pump in a system runs at full speed day and night. The ALPHA2 (N) from Grundfos adapts to the variable demand while keeping your comfort, saving a considerable amount of electricity. The installation of a GRUNDFOS ALPHA2 (N) pump will decrease the power consumption considerably, reduce noise from radiator valves and similar fittings, and improve the control of the system. The unique Grundfos AUTOADAPT function ALPHA2 (N) will analyse and adjust automatically to your heating and water use demands. Available in in both stainless steel for hot water (open) systems and cast iron for heating (closed) systems.



FEATURES

Robust design

The pump is made of materials that ensure excellent corrosion resistance. Designed for open systems Alpha2 N is constructed from quality stainless steel with a high grade composite impeller. The Alpha2 is constructed from rugged cast iron and is the perfect choice for closed systems.

Quiet operation

Permanent magnet motor provides an operating noise level at less than 43 decibels, the Alpha2 is whisper quiet.

AUTOADAPT

The pump learns the user pattern of the customer and learns from it. It only runs when hot water is needed.

Energy efficient

The reduction in power consumption has been achieved by using the latest permanent magnet motor technology.

APPLICATIONS

- Heating systems

PERFORMANCE

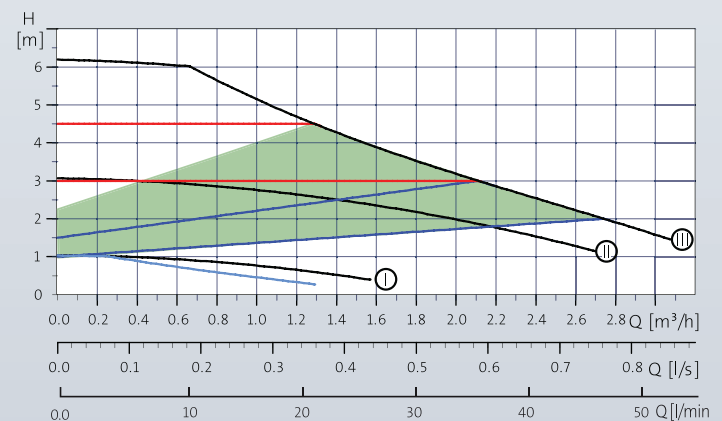

DIMENSIONS

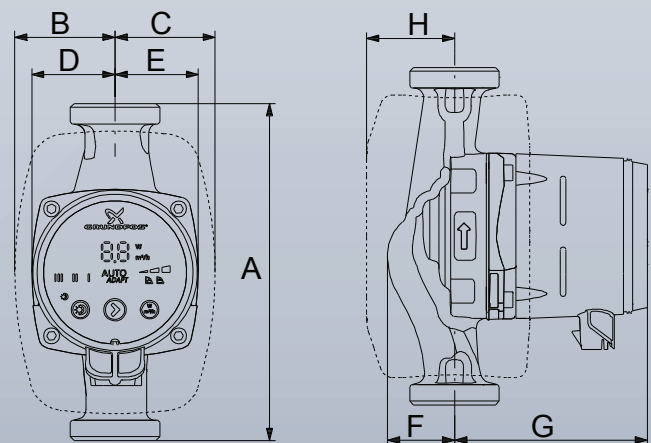

OPERATING CONDITIONS

System pressure

10 bar

Liquid temperature

2 to 110 °C

Ambient temperature

40 °C

Relative air humidity

95 %

TECHNICAL DATA

Mains voltage

1 x 240 V, 50 Hz

Enclosure class

IP44

Insulation class

F

Sound pressure level

43 dB

Approvals and markings

AS4020

Model	Connection size	Dimensions (mm)								Weight (kg)
		A	B	C	D	E	F	G	H	
Alpha2 (N) 25-60 130	¼" F	130	60.5	60.5	44.5	44.5	35.8	103.5	52	2.0
Alpha2 (N) 25-60 180	¼" F	180	60.5	60.5	44.5	44.5	35.8	103.5	52	2.0

BasicLine

by GRUNDFOS



The **BasicLine** by Grundfos range of pumps and tanks offer customers value for money, reliable solutions for basic applications including:

- ✓ **Water Supply**
- ✓ **Drainage**
- ✓ **Transfer**
- ✓ **Ground Water Supply**

Based on the proven design and performance of the Grundfos home and garden range, BasicLine by Grundfos is ideal for those looking for affordable pumping solutions without compromise on quality.

Constructed from durable materials for a long life, BasicLine by Grundfos pumps feature basic controls to customise pump settings and all products within the extensive range are backed by industry standard warranty.

PRODUCT PAGES

CMBasic	31 - 32
JPB	33 - 34
JPC	35 - 36
PMRain	37 - 38
Pressure Tanks	39 - 40
SB	41 - 42
SBA	43 - 44
SQN	45 - 46
UNILIFT CC	47 - 48
UNILIFT AP 35B & 50B	49 - 50
NS	51 - 52
JPA PT	53 - 54
JPD	55 - 56
Fire Warrior	57 - 58

CMBasic



The BasicLine by Grundfos CMBasic is a compact booster pump designed for domestic and light industrial use. The booster unit consists of a Grundfos CM cast iron pump with stainless steel hydraulic components and PM1 Pressure Manager. The Pressure Manager allows the pump to start and stop automatically according to demand and protects the pump from dry running.



FEATURES

Robust design

All moving parts are made from high quality, corrosion resistant stainless steel to ensure the longest life possible.

User-friendly interface

The pump features a user-friendly interface with LED indicators displaying power status, pump running, and alarm indication.

Protective features

The pump incorporates a range of protective features such as dry run protection, thermal overload protection, and cycling alarm to protect the pump and ensure a long life.

Easy installation

The booster unit is a compact solution, which makes it suitable for most installations. Simply connect the inlet and outlet and you have a fully operational booster unit.

Integrated non-return valve

Non-return valve for backflow prevention.

APPLICATIONS

- Household water supply
- Boosting from above ground water tanks
- Light industrial use



PERFORMANCE

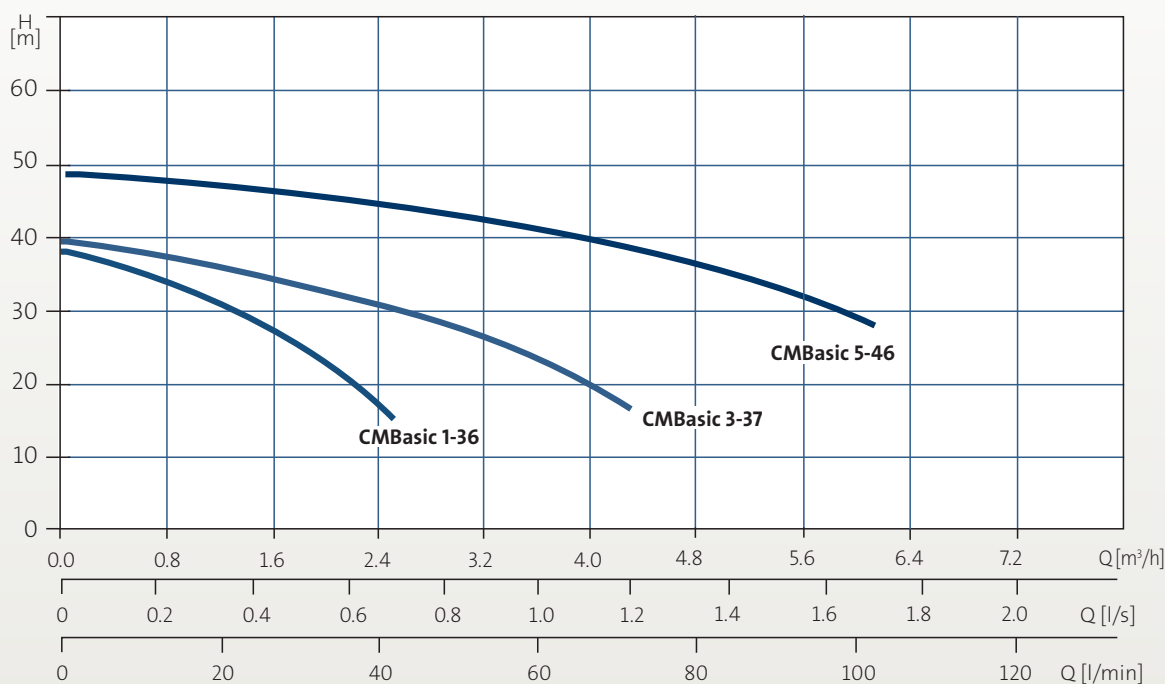

OPERATING CONDITIONS

System pressure

Max. 10 bar

Liquid temperature

0 °C to 60 °C

Ambient temperature

Max. 55 °C

Relative air humidity

Max. 95 %

TECHNICAL DATA

Mains voltage

1 x 240 V, 50 Hz

Enclosure class

IP55

Insulation class

F

Sound pressure level

50-60 dB

Start/stop frequency

Max. 100 per hour

Approvals and markings

CE

DIMENSIONS

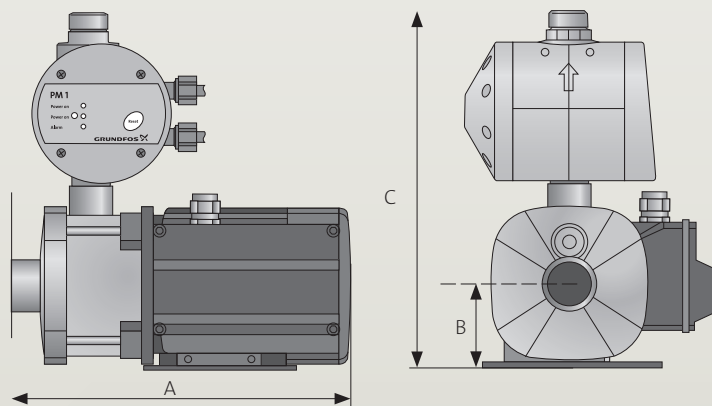

Model	Power (kW)	Connections		Dimensions (mm)			Weight (kg)
		Outlet	Inlet	A	B	C	
CMBasic 1-36	0.5	1" M	1" F	323	75	317	13.3
CMBasic 3-37	0.5	1" M	1" F	323	75	317	13.3
CMBasic 5-46	0.9	1" M	1¼" F	381	75	317	16.0



The BasicLine by Grundfos JPB is a compact self-priming booster solution for domestic water supply. It consists of a robust single-stage jet pump and is available with a Pressure Manager. Together these components ensure great comfort by automatically starting and stopping the pump according to your demand. Furthermore, the booster unit offers integrated protective functions protecting your investment. The JPB is easy to install, a simple matter of plug and pump. The JP5 & 6 are also available as a bare pump without the pressure manager.



FEATURES

Self-priming

With a suction-lift up to 7 metres, this booster unit is ideal for pumping from below ground level. This feature makes the booster unit suitable for a large variety of installations.

Robust design

The pump is made with materials that ensure excellent corrosion resistance. The pump housing and impeller are made of high quality stainless steel, while the rest of the pump is electrophoretically painted.

User-friendly interface

The booster versions include a user-friendly interface with LED indicators which shows, power on, pump running and alarm indication.

Protective features

The Pressure Manager incorporates features to protect both the pump and installation including dry running protection and cycling alarm.

Easy installation

The booster unit is a compact solution, which makes it suitable for most installations. Simply connect the inlet and outlet and you have a fully operational booster unit.

Integrated non-return valve

No additional fittings required for an above ground tank installation.

APPLICATIONS

- Below and above ground water source with a suction lift up to 7 metres



PERFORMANCE

JP 5 and JP 6

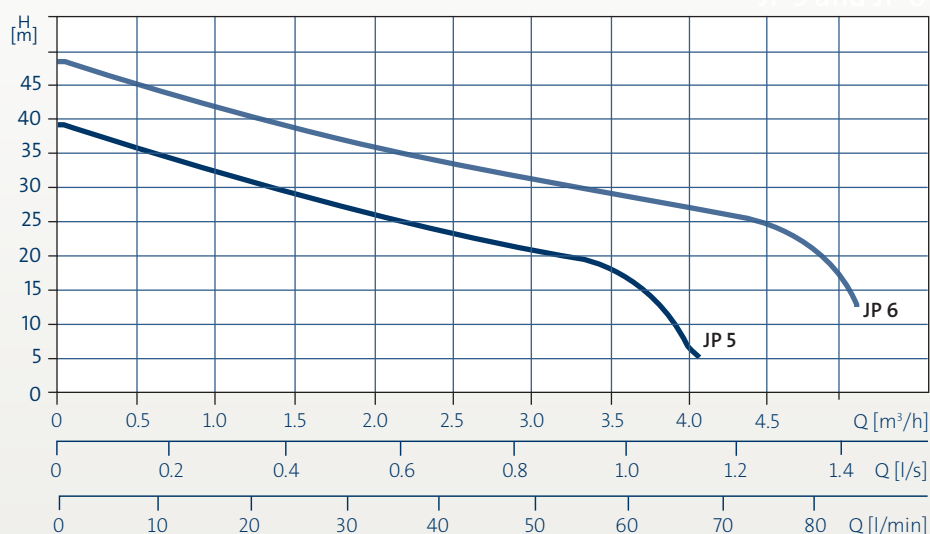

OPERATING CONDITIONS

System pressure

Max. 6 bar

Suction lift

Max. 7 metres, including suction pipe pressure loss at a liquid temperature of 20 °C

Liquid temperature

0 °C to 40 °C

Ambient temperature

-20 °C to 45 °C

Relative air humidity

Max. 95 %

DIMENSIONS

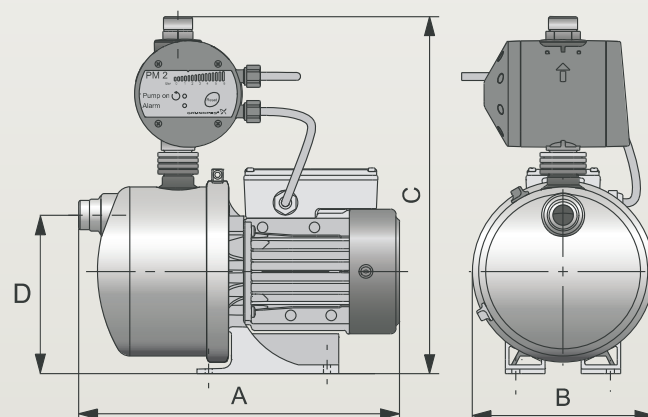

TECHNICAL DATA

Mains voltage

1 x 240 V, 50 Hz (JP Booster PM)

Enclosure class

IP44

Insulation class

F

Sound pressure level

72 dB

Start/stop frequency

Max. 100 per hour

Approvals and markings

CE, C-tick, GHOST TR

Model	Power (kW)	Connections		Dimensions (mm)				Weight (kg)
		Outlet	Inlet	A	B	C	D	
JP 5	0.48	1" M	1" M	364	206	411	240	8.5
JP 6	0.92	1" M	1" M	401	206	411	240	10.0



The BasicLine by Grundfos JPC is a compact booster pump designed for domestic and garden use. The booster unit consists of a Grundfos JPC self-priming, composite, single-stage jet-pump, with PM1 Pressure Manager. The Pressure Manager allows the pump to start and stop automatically according to demand and protects the pump from dry running.

The JPC is also available with a pressure tank and switch or bare pump with no controller.



FEATURES

Self-priming

With a suction-lift up to 7 metres, this pump is ideal for transferring water from wells or ground tanks. This feature makes this pump ideal for a large variety of installations.

Robust design

The materials of the pump are lightweight and ensure excellent corrosion resistance.

Protective features

The Booster version incorporates functions to protect both the pump and installation. These protective functions are dry running protection and cycling alarm.

Stable operation

The pump ensures stable operation with excellent suction capacity even when there are air bubbles and small sandy impurities in the water.

User friendly interface

The booster versions includes a user-friendly interface with LED indicators which shows, power on, pump running and alarm indication.

APPLICATIONS

- Domestic rainwater

TECHNICAL DATA

Mains voltage

1 x 240 V, 50 Hz

Enclosure class

IP65

Insulation class

F

Sound pressure level

JPC 2: 83 dB

JPC 3: 85 dB

JPC 4: 88 db

Start/stop frequency

Max. 20 per hour

Approvals and markings

C-tick, CE, GOST

PERFORMANCE

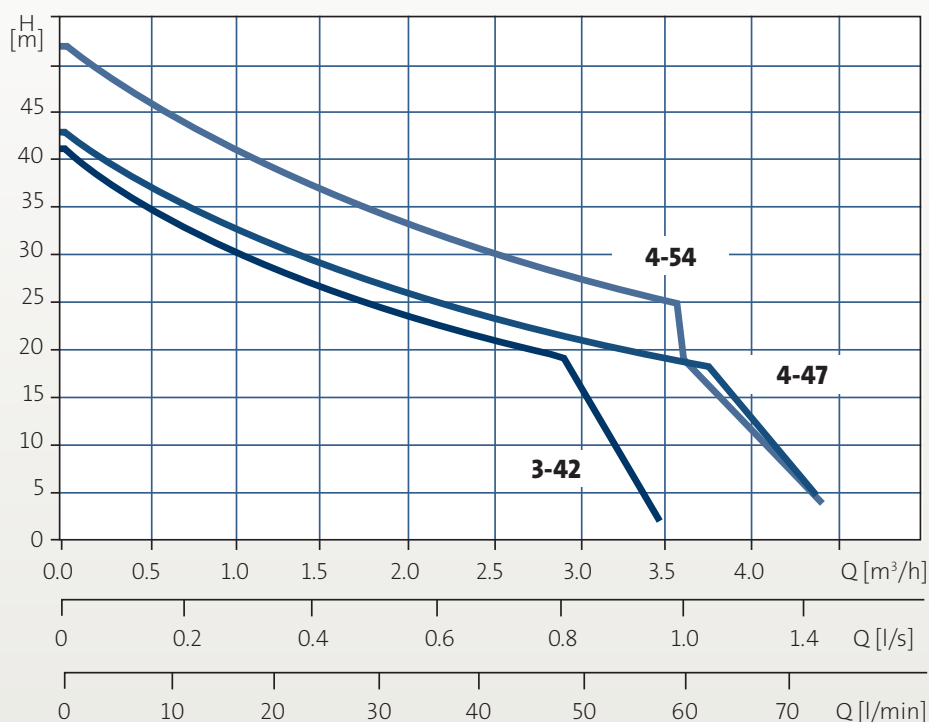

OPERATING CONDITIONS

System pressure

Max. 6 bar

Suction lift

Max: 8 metres, including suction pipe pressure loss at a liquid temperature of 20 °C

Liquid temperature

0 °C to 35 °C

Ambient temperature

Max. 40 °C

Relative air humidity

Max. 95 %

DIMENSIONS

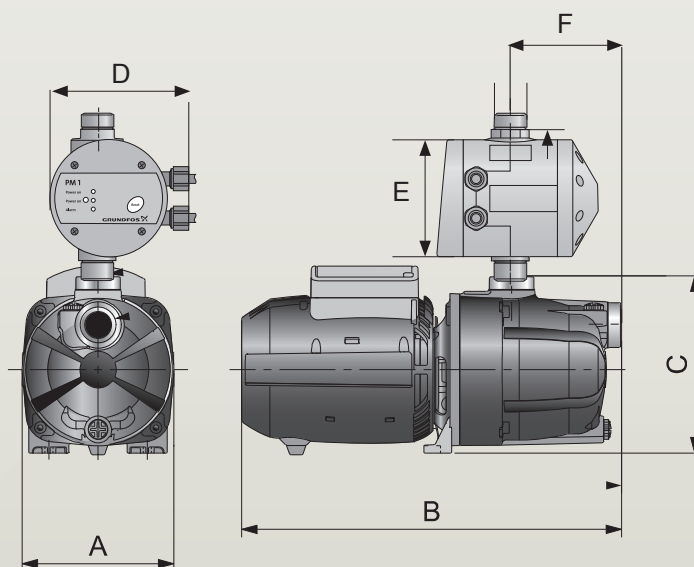

Model	Power (kW)	Connections		Dimensions (mm)						Weight (kg)
		Outlet	Inlet	A	B	C	D	E	F	
JPC3-42 PM1	0.44	1" M	1" F	170	406	360	143	120	122	8.0
JPC4-47 PM1	0.60	1" M	1" F	170	406	360	143	120	122	8.5
JPC4-54 PM1	0.75	1" M	1" F	230	425	365	143	120	122	10.5

PM Rain



The BasicLine by Grundfos PM Rain is a rain water harvesting device based on the Pressure Manager and is used in conjunction with a Grundfos pump. It ensures that all collected rainwater is used as first priority instead of precious drinking water, on applications such as toilets, laundry and watering the garden. It automatically starts the pump when it senses a demand and will switch over to mains water when your rainwater tank is empty or in the case of an electrical failure. Installation of the PM Rain is easy, simply connect it to your pipework.

No level sensor is needed for the rainwater tank.



FEATURES

Easy installation

The PM Rain incorporates a specially designed valve, which eliminates the need for a level sensor in the rainwater tank. This reduces installation time and cost.

Certified for drinking water

The PM Rain is WaterMark approved, and suitable for direct plumbing with main water.

User-friendly display

The PM Rain features a user-friendly display with LED indicators showing pump on, warning and indication of whether water is drawn from the rainwater tank or mains water supply.

Protective functions

The PM Rain incorporates functions which protect both the pump and the installation. These protective functions are dry-running protection, cycling alarm.

Backflow prevention

PM Rain features dual non-return valve for the mains water supply. This ensures that there will be no backflow into the mains supply eliminating the risk of contamination.

APPLICATIONS

- Rainwater harvesting with mains water back up

OPERATING CONDITIONS

System pressure

Max. 10 bar

Liquid temperature

0 °C to 60 °C

Ambient temperature

0 °C to 55 °C

TECHNICAL DATA

Mains voltage

1 x 240 V, 50 Hz

Enclosure class

IP65

Pstart

2.5 to 6 bar

Pstop

Pstart+1 bar

Insulation class

B

Sound pressure level

55 dB

Approvals and markings

C-Tick, Watermark AS4020



DIMENSIONS

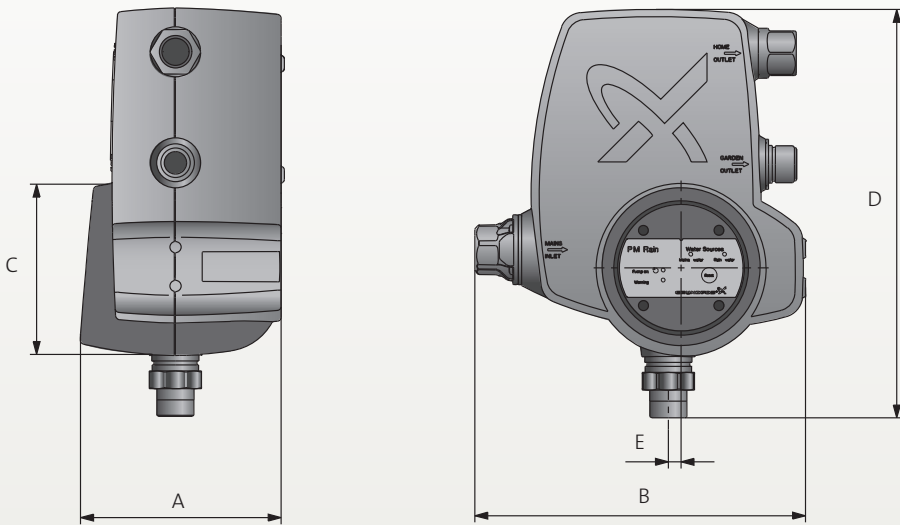

Model	Connections			Dimensions (mm)				
	Outlet (House)	Outlet (Garden)	Inlet	A	B	C	D	E
PMRain controller	¾" F	1" M	1" M	180	297	153	368	11



Pressure Tanks



The BasicLine by Grundfos GT pressure tanks for cold-water applications are longlife tanks for both domestic and industrial applications. The GT tank ensures controlled pressure in your water supply. The result of this is better comfort in your installation by limiting the start/stop frequency of your pump, compensation for pressure drops and eliminating water hammer in pipework. GT tanks can be integrated in many different installations with a wide variety of pumps. Grundfos offers a large range of tank types and sizes, ensuring the best possible tank for your installation.



FEATURES

Wide range of GT tanks

The GT tanks are available in sizes from 8 to 5,000 litres, suitable for vertical installation. GT tanks in sizes 24 to 80 litres are also suitable for horizontal installation.

Approved for drinking water

The Grundfos GT tanks are approved for use with drinking water.

Reducing start/stop frequency

The GT tanks ensure controlled pressure in the water supply and thereby limit the switching frequency of the pump in case of low water consumption or leakage loss.

Optimise comfort

The GT tanks increase system comfort by compensating for pressure drops when a tap is opened and reduce problems with water hammer in the pipework.

APPLICATIONS

- Boost of city mains, break tank or boost from well > 8 metres



PERFORMANCE

Model	Connection Size	Dimensions (mm)		Capacity (L)	Mounting type	Max pressure (kPa)
		Height	Diameter			
GT-H-2 PN10 G1 V	1" M	183	127	2	Pipe	1000
GT-H-8 PN10 G1 V	1" M	311	203	8	Pipe	1000
GT-H-18 PN10 G1 V	1" M	366	279	18	Pipe	1000
GT-H-18 PN16 G1 V	1" M	366	279	18	Pipe	1600
GT-H-60 PN10 G1 V	1" F	528	388	60	Free standing	1000
GT-H-80 PN10 G1 V	1" F	626	388	80	Free standing	1000
GT-H-80 PN16 G1 V	1" F	787	388	80	Free standing	1600
GT-H-100 PN10 G1 V	1" F	804	430	100	Free standing	1000
GT-D-130 PN10 G1 V	1¼" F	1101	406	130	Free standing	1000
GT-D-200 PN10 G1 1/4 V	1¼" F	1042	534	200	Free standing	1000
GT-U-200 PN16 G11 1/4 V	1¼" F	9967	634	200	Free standing	1600
GT-D-240 PN10 G1 1/4 V	1¼" F	1219	533	240	Free standing	1000
GT-D-300 PN10 G1 1/4 V	1¼" F	1575	533	300	Free standing	1000
GT-D-450 PN10 G1 1/4 V	1¼" F	1505	660	450	Free standing	1000

TANK RANGE

GT-H

GT-H is a steel pressure tank with a non-toxic butyl rubber diaphragm with a precision-moulded polypropylene liner for superior air and water separation.

GT-D

GT-D is a steel pressure tank with double diaphragm. The diaphragm is a chlorine-resistant 100% butyl diaphragm with a precision-moulded copolymer polypropylene liner for superior air and water separation.

OPERATING CONDITIONS

Max. operating pressure

Max. 10/16 bar

Liquid temperature

Max. 90 °C

TECHNICAL DATA

Approvals and markings

CE, GOST, NSF, WRAS, ACS, Worksafe certified

Tank pre charge recommended 10% below cut in pressure for PT systems; 70% of maximum pump pressure on PM1 and PM2 units and 70% of set point on variable speed pumps



The BasicLine by Grundfos SB pump is a submersible booster pump designed for the pumping of clean water for domestic and rainwater applications. The SB submersible pump is silent when submerged and therefore a noiseless alternative to surface mounted pumps. The SB pump is built of high quality composite and stainless steel materials that are resistant to corrosion. The SB is ideal for operation in a well or ground tanks, as it easily prevents solid particles from entering the pump. Furthermore, the pump features a flow switch which ensures the user a convenient experience with automatic start/stop operation and dry running protection of the pump.



FEATURES

Noiseless operation

The SB pump emits no noise when submerged and is therefore a noiseless alternative to non-submersible pumps.

Robust design

The SB pump is built of composite and stainless steel materials which are resistant to corrosion.

Thermal overload protection

The single-phase model is effectively protected against any accidental overload, by built in thermal protection.

Dry running protection

The SB pump is protected from dry running, by means of the function of the flow switch.

Automatic operation

The flow switch for the SB pump ensures automatic operation by means of the water level in tank.

APPLICATIONS

- Boosting from wells (less than 8 meters) and domestic rainwater



PERFORMANCE

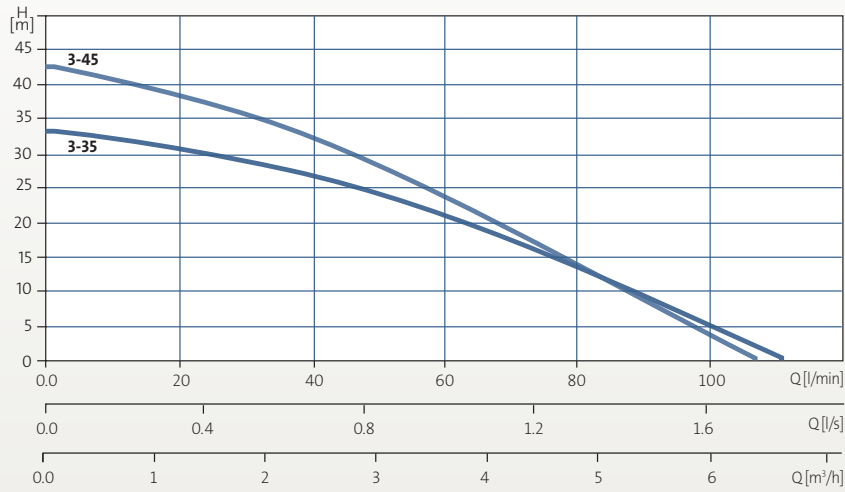

OPERATING CONDITIONS

Maximum particle size

1 mm

Ambient temperature

Max 50 °C

Liquid temperature

0 to 40 °C

pH-value range

4-9

TECHNICAL DATA

Mains voltage

1 x 240 V, 50 Hz

Insulation class

B

Enclosure class

IP68

Max installation depth

10 m

Approvals and markings

EAC, CSA, C-tick

DIMENSIONS

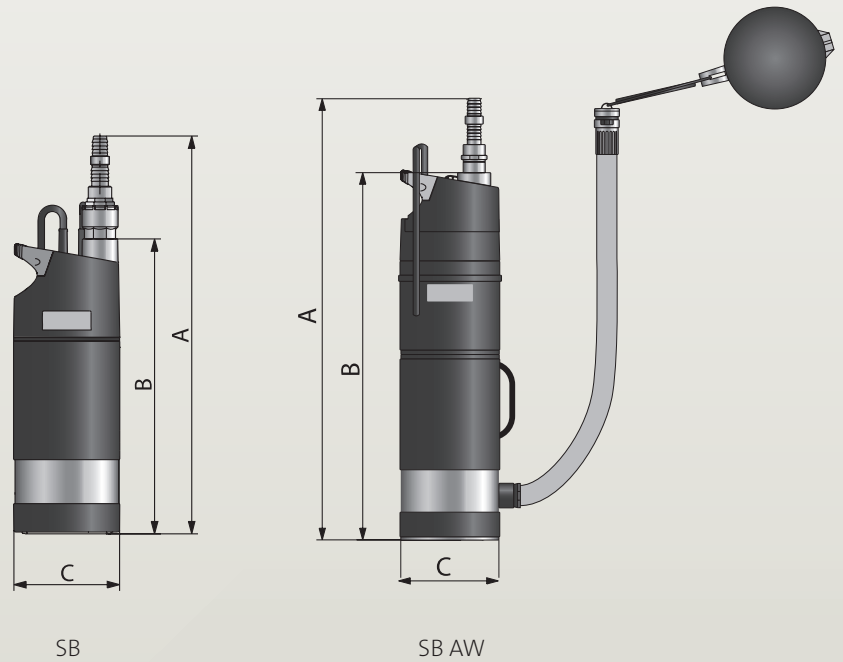

Model	Cable (m)	Power (kW)	Connection size	Dimensions (mm)			Weight (kg)
				A	B	C	
SB 3-35	15	0.8	1" F	536	390	150	9.4
SB 3-45	15	1.05	1" F	584	415	150	9.7
SB 3-35 AW	15	0.8	1" F	621	528	150	10.3
SB 3-45 AW	15	1.05	1" F	646	553	150	10.6



The BasicLine by Grundfos SBA pump is a submersible booster pump designed for the pumping of clean water for domestic and rainwater applications. The SBA submersible pump is silent when submerged and therefore a noiseless alternative to surface mounted pumps. The SBA pump is built of high quality composite and stainless steel materials that are resistant to corrosion. The SBA is ideal for operation in a well or ground tanks. Furthermore, the pump features a flow switch which ensures the user a convenient experience with automatic start/stop operation and dry running protection of the pump.



FEATURES

Automatic control unit

Integrated control unit eliminates the need for an external pump controller - simply plug-and-pump.

Noiseless operation

The SBA pump emits no noise when submerged and is therefore a noiseless alternative to non-submersible pumps.

Robust design

The SBA pump is built of composite and stainless steel materials which are resistant to corrosion.

Integrated protection

SBA features integrated float switch for dry-running protection.

Automatic restart

SBA with float switch automatically restarts when water is added.

Overheat protection

Built-in thermal protection immediately stops the pump if it overheats. Having cooled down, the pump automatically restarts when it reaches a normal temperature.

Longer life

A Grundfos float switch prevents air from entering the system as a result of dry running.

APPLICATIONS

- Boosting from wells (less than 8 meters) and domestic rainwater tanks



PERFORMANCE

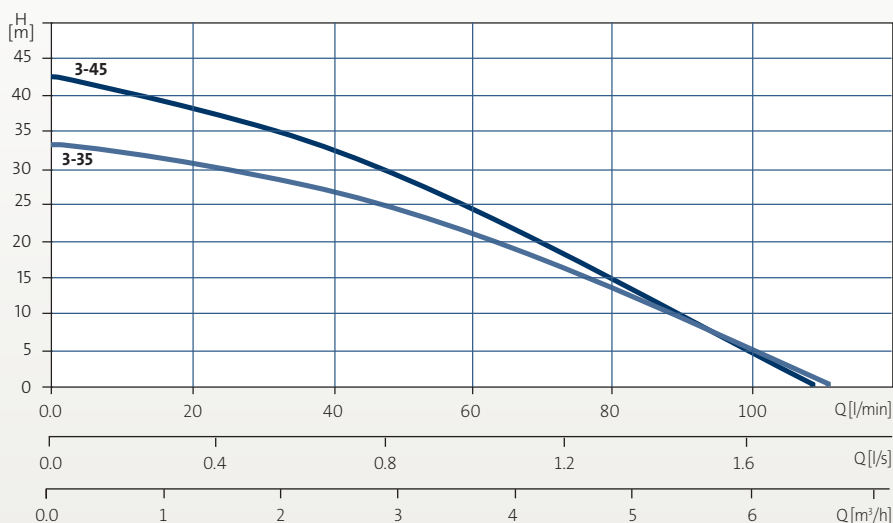

OPERATING CONDITIONS

Maximum particle size

1 mm

Ambient temperature

Max 50 °C

Liquid temperature

0 to 40 °C

pH-value range

4-9

TECHNICAL DATA

Mains voltage

1 x 240 V, 50 Hz

Insulation class

B

Enclosure class

IP68

Max installation depth

10 m

Approvals and markings

EAC, CSA, C-tick, CE

DIMENSIONS

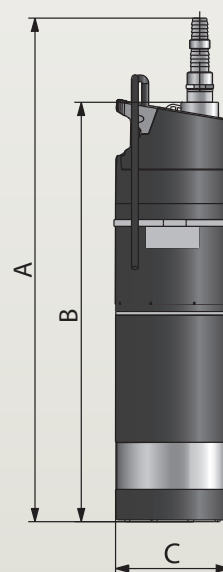

Model	Cable (m)	Power (kW)	Connection size	Dimensions			Weight (kg)
				A	B	C	
SBA 3-35	15	0.8	1" F	621	528	150	10.9
SBA 3-45	15	1.05	1" F	646	553	150	11.1



The BasicLine by Grundfos SQN is a small and compact submersible multi-stage pump designed for constant pressure operation in domestic applications. The motor of the SQN pump is a permanent magnet motor with a micro frequency converter ensuring optimum efficiency. The built-in frequency converter features protective functions and soft-starting, which reduces starting current and gives smooth and steady acceleration and dry running protection. The SQN pump is handy and user-friendly due to its low weight and 3-inch diameter.



FEATURES

High Efficiency

The SQ pump is fitted with high efficiency permanent magnet motor that ensure lower running cost while providing higher starting torque to ensure the pump starts every time.

Excellent starting capabilities

The soft starter minimises the risk of wear on the pump and prevents overloading of the mains during start-up. Its soft-start system also reduces water hammering, light flickering and other electrical disturbances.

Overvoltage and undervoltage protection

The integrated protection prevents damage to the motor in case the supply voltage moves outside the permissible voltage range.

Overload protection

The SQN eliminates the need for motor protection. If the pump is exposed to heavy load the motor will automatically reduce its speed, or if the pump is blocked it automatically stops pumping.

Over-heating protection

As an extra protection, the electronic unit has a built-in temperature sensor. When the temperature exceeds a critical limit, the pump is stopped and when the temperature has dropped, the pump automatically starts.

Protection against upthrust

The SQN is fitted with an upthrust bearing protecting both pump and motor against upthrust, thus preventing breakdown during the critical start-up phase.

OPERATING CONDITIONS

pH values

5 to 8

Liquid temperature

0 °C to 35 °C

TECHNICAL DATA

Mains voltage

1 x 240 V, 50 Hz

Enclosure class

IP68

Insulation class

F

Installation depth

Max. 150 m below static water level

Pump diameter

74 mm

Borehole diameter

Min. 76 mm

Approvals and markings

CE, UL, cUL

PERFORMANCE

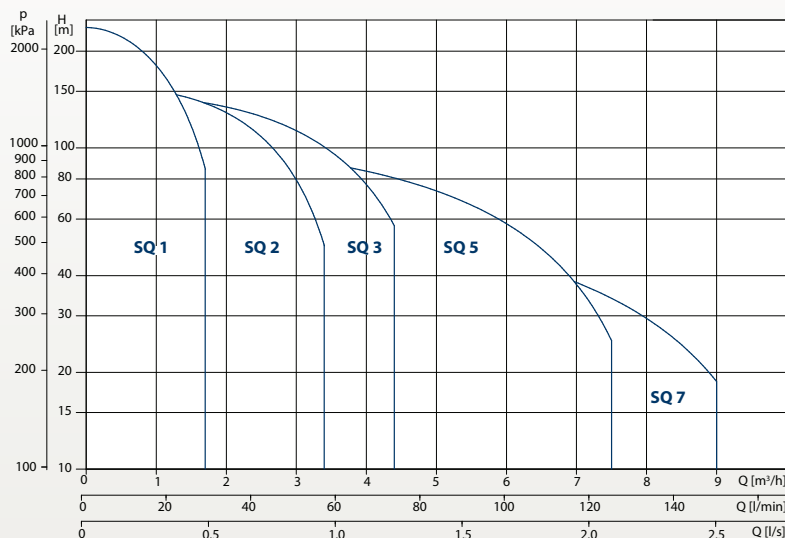

Model	Power-P2 (kW)	Max Current (A)	Outlet	Dimensions (mm)			Weight (kg)
				A	B	C	
SQ 1-35 N	0.7	2.5	1 ¼"	741	265	74	4.7
SQ 1-50 N	0.7	3.3	1 ¼"	741	265	74	4.8
SQ 1-65 N	0.7	4.3	1 ¼"	768	592	74	4.9
SQ 1-80 N	1.15	5.1	1 ¼"	825	346	74	5.6
SQ 1-95 N	1.15	6.0	1 ¼"	825	346	74	5.6
SQ 1-110 N	1.15	7.0	1 ¼"	852	373	74	5.7
SQ 1-125 N	1.68	7.8	1 ¼"	942	427	74	6.4
SQ 1-140 N	1.68	8.6	1 ¼"	942	427	74	6.5
SQ 1-155 N	1.85	9.6	1 ¼"	969	454	74	6.7
SQ 2-35 N	0.7	3.0	1 ¼"	741	265	74	4.7
SQ 2-55 N	0.7	4.3	1 ¼"	741	265	74	4.8
SQ 2-70 N	1.15	5.5	1 ¼"	768	292	74	5.4
SQ 2-85 N	1.15	6.8	1 ¼"	825	346	74	5.5
SQ 2-100 N	1.68	8.0	1 ¼"	861	346	74	6.2
SQ 2-115 N	1.85	9.3	1 ¼"	888	373	74	6.3
SQ 3-30 N	0.7	3.0	1 ¼"	741	265	74	4.8
SQ 3-40 N	0.7	4.2	1 ¼"	741	265	74	4.8
SQ 3-55 N	1.15	5.4	1 ¼"	768	292	74	5.4
SQ 3-65 N	1.15	6.7	1 ¼"	825	346	74	6.1
SQ 3-80 N	1.68	7.8	1 ¼"	861	346	74	6.3
SQ 3-95 N	1.68	9.0	1 ¼"	888	373	74	6.4
SQ 3-105 N	1.85	10.3	1 ¼"	942	427	74	6.5
SQ 5-15 N	0.7	2.3	1 ½"	743	265	74	4.7
SQ 5-25 N	0.7	3.9	1 ½"	743	265	74	4.8
SQ 5-35 N	1.15	5.6	1 ½"	824	346	74	5.5
SQ 5-50 N	1.68	7.3	1 ½"	260	346	74	6.1
SQ 5-60 N	1.68	8.9	1 ½"	941	427	74	6.4
SQ 5-70 N	1.85	10.7	1 ½"	941	427	74	6.4
SQ 7-15 N	0.7	3.1	1 ½"	743	265	74	4.7
SQ 7-30 N	1.15	5.5	1 ½"	743	265	74	5.2
SQ 7-40 N	1.68	7.8	1 ½"	860	346	74	6.1

DIMENSIONS

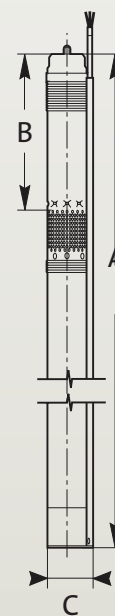

UNILIFT CC



The BasicLine by Grundfos UNILIFT CC is a lightweight single-stage drainage pump with a semi-open impeller. They are designed for pumping drain water and grey wastewater containing particles up to a size of up to 10 mm. The suction strainer at the bottom of the pump prevents particles larger than the pump is designed for from entering. The strainer is made of stainless steel, while the main pump parts, e.g. the sleeve and pump housing, are made of moulded composite materials. The UNILIFT CC can pump down to a water level of 3 mm above the floor by removing the strainer and can be used in permanent installations or as a portable pump.



FEATURES

Prevention of backflow

The pump is supplied with an adapter and a non-return valve to prevent backflow through the pump when it stops.

Robust design

The materials of the pump ensure excellent corrosion resistance. Furthermore, the CC 7 and 9 have a built in V-ring mechanical shaft seal which offers wear resistance and a long operating life.

Thermal overload protection

The single-phase version is effectively protected against any accidental overload, by built-in thermal protection. This means that no additional motor protection is required.

Auto-restart

In case the motor cuts out due to thermal overload, the motor automatically starts again when it has cooled to normal temperature.

Handy and easily transportable

The light weight of the pump and the carry handle mounted on the housing make it handy and easily transportable.

Automatic operation

The pump has a float switch for automatic on/off operation between two liquid levels.

Self-venting valve

The UNILIFT CC 7 features a self-venting valve. Place the pump underwater, engage the power, and relax. The self-venting valve located in the handle prevents air from getting trapped in the pump.

Good connectivity

Includes multiple adapter for thread sizes from 3/4" to 1/1/4"

APPLICATIONS

- Domestic wastewater

PERFORMANCE

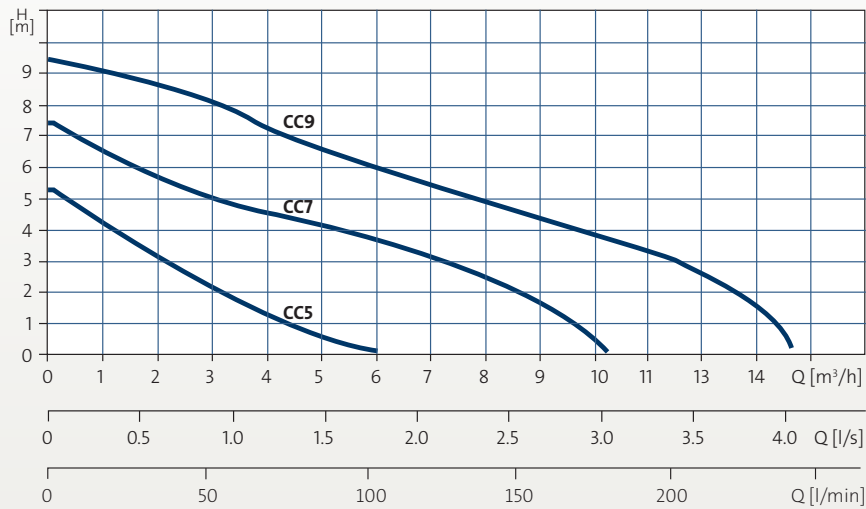

OPERATING CONDITIONS

Liquid temperature

0 °C to 40 °C

Max. particle size

Ø10 mm

pH concentration

4 to 9

Max. installation depth

10 m

TECHNICAL DATA

Mains voltage

1 x 240 V, 50 Hz

Enclosure class

IP68

Insulation class

B (UNILIFT CC 5 & CC 9)

F (UNILIFT CC 7)

Cable type

H07RN-F

Approvals and markings

VDE, CSA, GOST and LGA according to DIN EN 12050-2

DIMENSIONS

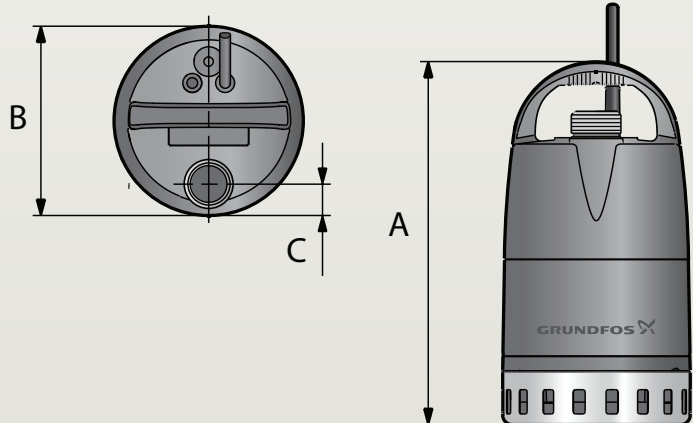

Model	Cable length (m)	Power - P2 (kW)	Connection size	Dimensions (mm)			Weight (kg)
				A	B	C	
UNILIFT CC 5	10	0.25	1¼" M	306.6	160	26.5	4.35
UNILIFT CC 7	10	0.38	1¼" M	306.6	160	26.5	4.60
UNILIFT CC 9	10	0.78	1¼" M	306.6	160	26.5	6.5

UNILIFT AP 35B & 50B



The BasicLine by Grundfos UNILIFT AP Basic pumps are single-stage pumps with a vortex impeller. The pumps are designed for pumping dirty water, untreated wastewater containing particles up to a size of Ø50 mm, depending on the pump size.

All UNILIFT AP Basic pumps are made of stainless steel with a composite baseplate. The UNILIFT AP Basic range is designed for submerged operation, either free-standing or on the base plate. In addition the pumps are suitable for installations on auto couplings, which allows easy access to the pump for maintenance and other purposes. All UNILIFT AP Basic pumps can be supplied with or without float switch, for automatic or manual operation.



FEATURES

Robust design

The materials of the pump ensure excellent corrosion resistance. The pump housing and impeller are made of high quality stainless steel. Furthermore, the mechanical shaft seal offers high-wear resistance and a long operating life.

Thermal overload protection

The single-phase version is effectively protected against any accidental overload by built-in thermal protection. This means that no additional motor protection is required.

Option for automatic operation

The pumps are available with float switches for automatic on/off operation.

Auto coupling

UNILIFT AP Basic pumps are suitable for installation on an auto coupling at the bottom of a collecting tank with guide rails going to the top. A guide rail system is available from Grundfos as an accessory.

OPERATING CONDITIONS

Liquid temperature

0 °C to 40 °C

Max. particle size

AP35 - 35 mm and AP50 - 50 mm particle size

pH concentration

4 to 10

Max. installation depth

7 m

TECHNICAL DATA

Mains voltage

1 x 240 V, 50 Hz
3 x 415 V, 50 Hz

Enclosure class

IP68

Insulation class

F

Cable type

H07RN-F

Approvals and markings

VDE, LGE, UL and CSA

UNILIFT AP 35B & 50B

PERFORMANCE

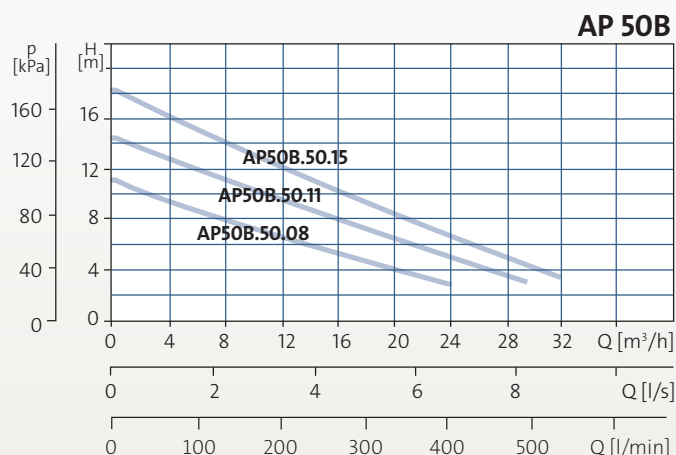
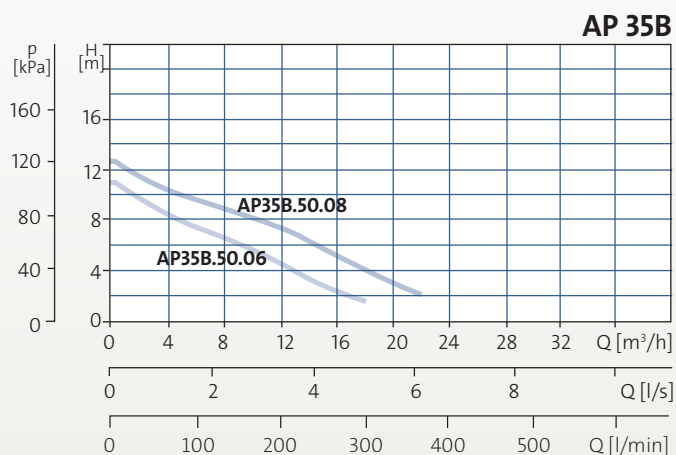

DIMENSIONS

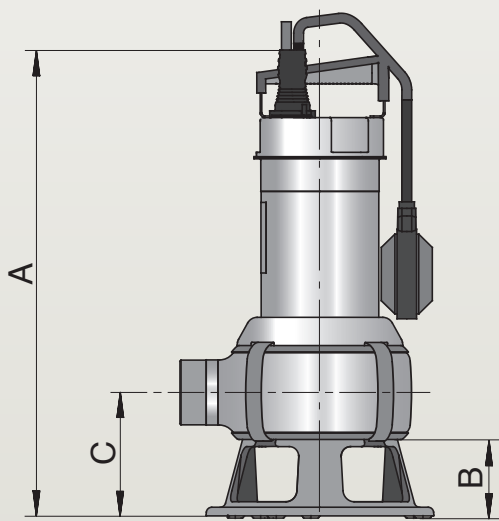

Model	Cable length (m)	Power (kW)	Connection size	Dimensions (mm)			Weight (kg)
				A	B	C	
UNILIFT AP35B-50.06-A1V	10	0.66	2" F	443	73	116	10.3
UNILIFT AP35B-50.08-A1V	10	0.71	2" F	468	73	116	11.8
UNILIFT AP50B.50.08.A1V	10	0.74	2" F	468	73	116	10.1
UNILIFT AP50B.50.11.A1V	10	1.1	2" F	468	73	116	10.2
UNILIFT AP50B.50.11.3V	10	1.3	2" F	468	73	116	9.7
UNILIFT AP50B.50.15.3V	10	1.5	2" F	468	73	116	10



BasicLine by Grundfos NS duty centrifugal irrigation and water transfer pumps are ideal for pumping clear water and other non-aggressive liquids. Available in single-impeller and twin-impeller, these efficient pumps are constructed from robust materials to ensure a long life. All single-phase versions have built-in overload protection.



FEATURES

Robust Construction

Pump body and motor constructed from anti-corrosive materials to provide the longest life possible.

Quiet

Enclosed fan-cooled induction motor and rotor mounted on oversized greased-for-life ball bearings to ensuring quiet operation and a long life.

Built in Overload protection

All single-phase versions have built-in overload protection for added protection.

OPERATING CONDITIONS

System pressure

Max. 6 Bar (NS 3-40, NS4-23, NS5-33, NS30-18)

Max. 8 Bar (NS 5-60)

Liquid temperature

0 °C to 35 °C

Ambient temperature

Max. 40 °C

APPLICATIONS

- Boosting from above ground water tanks
- Light industrial use

TECHNICAL DATA

Mains voltage

1 x 240 V, 50 Hz

3 X 415 V, 50 Hz

Enclosure class

Motor: IP44

Terminal Box: IP55

Insulation class

F

Approvals and markings

C-tick, CE



PERFORMANCE

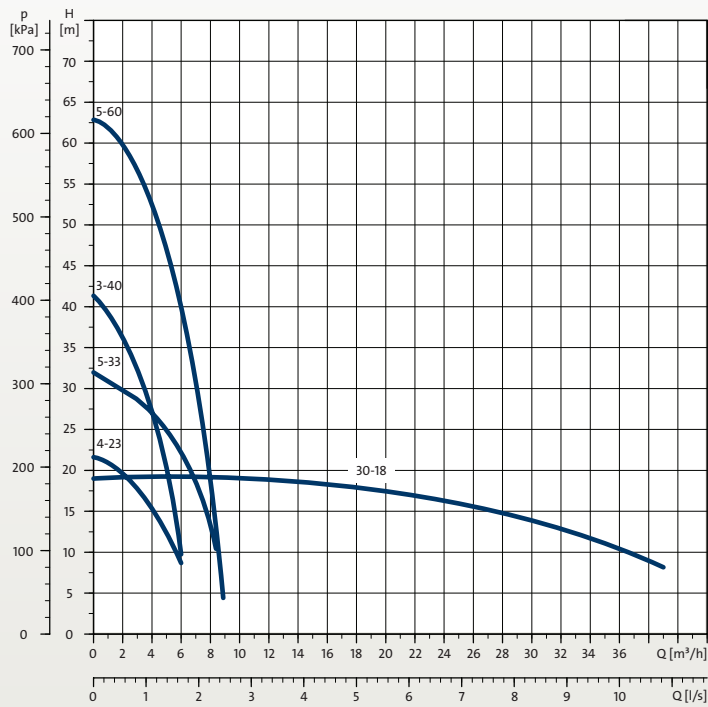

DIMENSIONS

NS 30-18

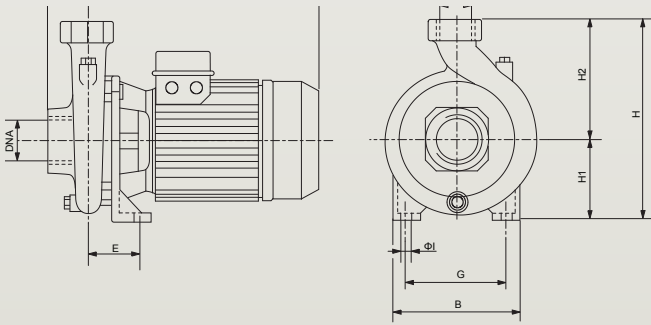

NS 30-40, 4-23, 5-33 & 5-60

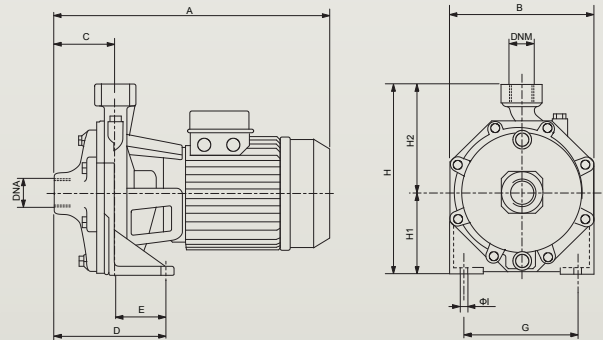

Model	Power (kW)	Connections		Dimensions (mm)								Weight (kg)
		Outlet	Inlet	A	B	C	E	G	H	H1	H2	
1 x 240 V, 50 Hz												
NS3-40	1.2	1 F	1 F	362	180	76	75	148	235	100	135	15
NS4-23	0.65	1 F	1 F	275	160	50	50	110	205	85	120	10
NS5-33	1.3	1 F	1 F	330	185	50	58	140	2335	100	135	15
NS5-60	2.7	1 ¼ F	1 F	370	210	75	69	165	268	118	150	25
NS30-18	1.85	2 F	2 F	430	200	62	74	120	270	105	165	23
3 X 415 V, 50 Hz												
NS30-18	2.1	2 F	2 F	358	200	62	74	120	270	105	165	23

JPA PT



The BasicLine by Grundfos JPA PT is a booster consisting of a JPA pump, a pressure switch, a pressure gauge and a diaphragm tank.

The pressure switch automatically starts the pump according to demand and the diaphragm tank increases system comfort by compensating for pressure drops when a tap is opened and helps to reduce problems with water hammer in the pipework.



FEATURES

Robust construction

Cast iron construction to provide the longest life possible.

Self Priming

Built-in ejector with guide vanes for optimum self-priming up to 8m.

Constant Water Supply

The diaphragm tank ensures a constant water pressure in the water supply and thereby limits the switching frequency of the pump in case of low water consumption or leakage loss.

Automatic start / stop

The pressure switch automatically starts the pump according to demand.

Built in protection

Built-in thermal and current protection to help ensure a long life.

APPLICATIONS

- Boosting from above ground water tanks
- Boosting from below ground water sources
- Light industrial use



PERFORMANCE

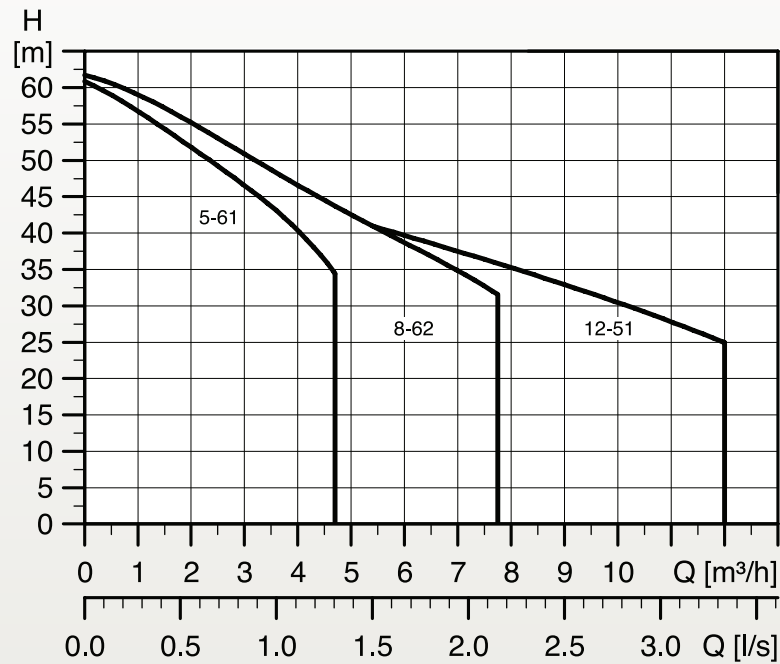

OPERATING CONDITIONS

System pressure

Max. 8 bar

Suction lift

Max: 8 metres, including suction pipe pressure loss at a liquid temperature of 20 °C

Liquid temperature

0 °C to 35 °C

Ambient temperature

Max. 40 °C

Relative air humidity

Max. 95 %

DIMENSIONS

JPA 5-61 PT
& JPA 8-62 PT

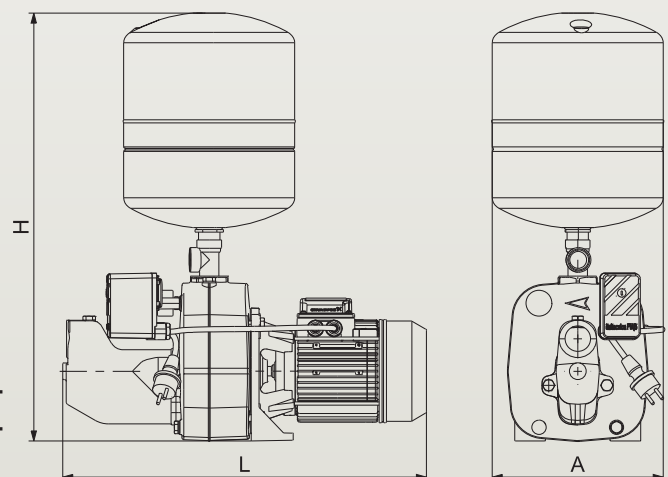

TECHNICAL DATA

Mains voltage

1 x 240 V, 50 Hz

Enclosure class

IP44

Insulation class

F

Sound pressure level

Below 77 dB(A)

Start/stop frequency

Max. 20 per hour

Approvals and markings

C-tick, CE, GOST

JPA 12-51 PT

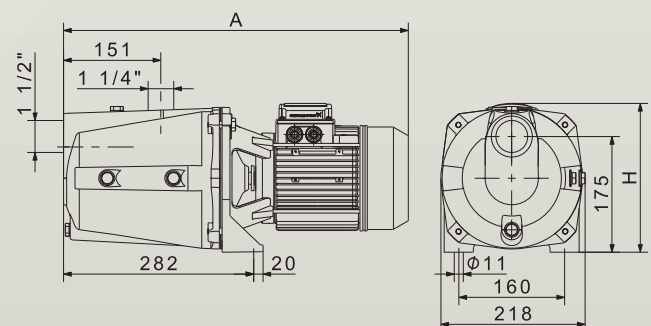

Model	Power (kW)	Connections		Dimensions (mm)			Weight (kg)
		Outlet	Inlet	A	L	H	
JPA 5-61PT	1.6	1	1¼	264	563	662	29
JPA 8-62PT	2.2	1	1¼	264	637	662	33
JPA 12-51PT	2.7	1¼	1½	595	-	230	29



The BasicLine by Grundfos JPD is a cast iron self-priming booster pump with suction capability of up to 27 meters.

Ideal for irrigation or wash-down applications, the JPD consists of a JPD pump, a pressure switch, a pressure gauge, a diaphragm tank and E 30 Ejector as standard (other ejectors available as options).



FEATURES

Robust construction

Cast iron construction to provide the longest life possible.

Self Priming

Supplied with E 30 Ejector as standard for self-priming up to 27 meters.

Constant Water Supply

The diaphragm tank ensures a constant water pressure in the water supply and thereby limits the switching frequency of the pump in case of low water consumption or leakage loss.

Automatic start / stop

The pressure switch automatically starts the pump according to demand.

APPLICATIONS

- Boosting from above ground water tanks
- Boosting from below ground water sources
- Light industrial use

PERFORMANCE

Hydraulic Data (n~2800 1/min.)											
Model	Ejector Type	Suction Depth	Delivery Pressure (bar)								
			3	3.5	4	4.5	5	5.5	6	6.5	7
			Capacity (l/h)								
JPD 5-61	E 20	9	3470	2890	2220	1500	750	-	-	-	-
		12	3110	2510	1850	1100	300	-	-	-	-
		15	2710	2100	1380	640	-	-	-	-	-
		18	2360	1700	950	-	-	-	-	-	-
	E 25	15	2800	2330	1830	1350	900	520	-	-	-
		18	2530	2050	1550	1090	680	300	-	-	-
		21	2280	1800	1300	860	470	-	-	-	-
		24	-	-	-	-	-	-	-	-	-
	E 30	21	1820	1650	1410	1160	910	700	520	-	-
		24	1680	1520	1260	1020	780	580	420	-	-
		27	1550	1360	1110	880	680	490	330	-	-
		27	-	-	-	-	-	-	-	-	-
JPD 8-62	E 20	9	4300	3600	2900	2180	1400	640	-	-	-
		12	3750	3140	2540	1700	940	-	-	-	-
		15	-	2780	2040	1300	500	-	-	-	-
		18	-	2340	1610	820	-	-	-	-	-
	E 25	15	-	2920	2400	1900	1400	950	570	-	-
		18	-	2600	2110	1620	1150	720	360	-	-
		21	-	2350	1850	1350	900	510	-	-	-
		24	-	2050	1550	1080	660	300	-	-	-
	E 30	21	-	-	1710	1480	1220	980	770	590	420
		24	-	-	1580	1330	1080	850	670	490	330
		27	-	-	1440	1200	950	750	560	400	250
		27	-	-	-	-	-	-	-	-	-

OPERATING CONDITIONS

System pressure

Max. 8 bar

Suction lift

Max. 27 m including inlet-pipe pressure loss at a liquid temperature of 20 °C

Liquid temperature

0 °C to 35 °C

Ambient temperature

Max. 40 °C

Relative air humidity

Max. 95 %

TECHNICAL DATA

Mains voltage

1 x 240 V, 50 Hz

Enclosure class

IP44

Insulation class

F

Sound pressure level

Below 77 dB(A)

Start/stop frequency

Max. 20 per hour

Approvals and markings

CE, GOST

DIMENSIONS

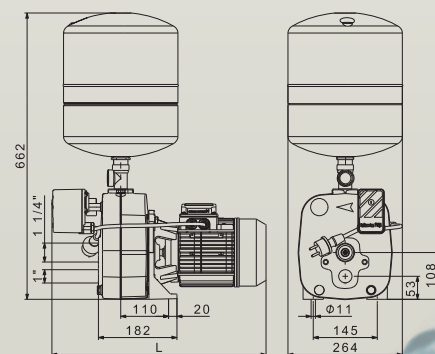
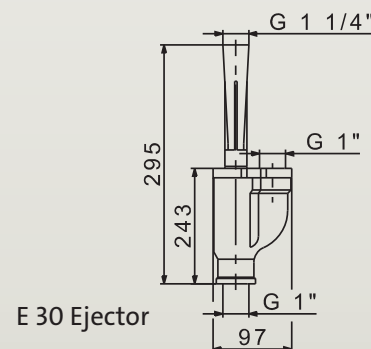

Model	Power (kW)	Dimensions (mm)
		L
JPD 5-61	1.56	495
JPD 8-62	2.1	571

Fire Warrior



The BasicLine by Grundfos Fire Warrior range of engine driven self-priming, centrifugal pumps are robust and reliable, making them suitable for a variety of applications. Available with a quality Lister diesel or genuine Honda Australia engines, the standard Fire Warrior range provides efficient water transfer for a range of applications including, firefighting, irrigation, boom spraying and tank filling.

The waste water (WW) version with genuine Honda engine is ideal for handling soft solids up to 25 mm and features a quick release system for rapid and efficient removal of debris from clogged impellers. The multipurpose (MP) version with genuine Honda engine comes complete with Viton® seals, making it ideal for pumping a variety of liquids.

FEATURES

Self-priming

Ideal for transferring water from above or below ground water sources.

Roll cage

Complete with roll cage as standard, allowing for easy transportation (excluding MP 27/120 P)

Quick release system

To allow for rapid and efficient removal of debris from clogged impellers (WW 15/1000 and WW 15/1400 only)

Hose kit option

2 x 6 m (¾") hoses with fire spray nozzles
1 x 4 m (1½") grey suction hose with strainer

ENGINE FEATURES

Honda Petrol Engine

- Genuine quality Honda Australia engine
- Oil Alert System to prevent engine damage caused by insufficient oil in the crankcase (except MP 27/120)
- Built to Australian emission specifications



PUMP



**HONDA
PETROL ENGINE**



**LISTER
DIESEL ENGINE**

Lister Diesel Engine

- Robust Australian Lister engine
- Electric start for an easy start up
- Variable speed to help save energy consumption
- Designed for continuous operation in ambient temperatures up to 40°C - ideal for the harsh Australian climate
- 100 hour service intervals for low maintenance

CONSTRUCTION

Wet end materials

- Aluminium suction cover, diffuser, impeller, casing and 3 way discharge
- Carbon / ceramic mechanical seal
- Stainless steel casing bolts

PERFORMANCE GRAPH

- FIRE WARRIOR MP 27/120 P
- FIRE WARRIOR 15/600 P
- FIRE WARRIOR 15/250 P
- FIRE WARRIOR WW 15/1400 P
- FIRE WARRIOR WW 15/1000 P
- FIRE WARRIOR 55/200 P
AND FIRE WARRIOR 55/200 D

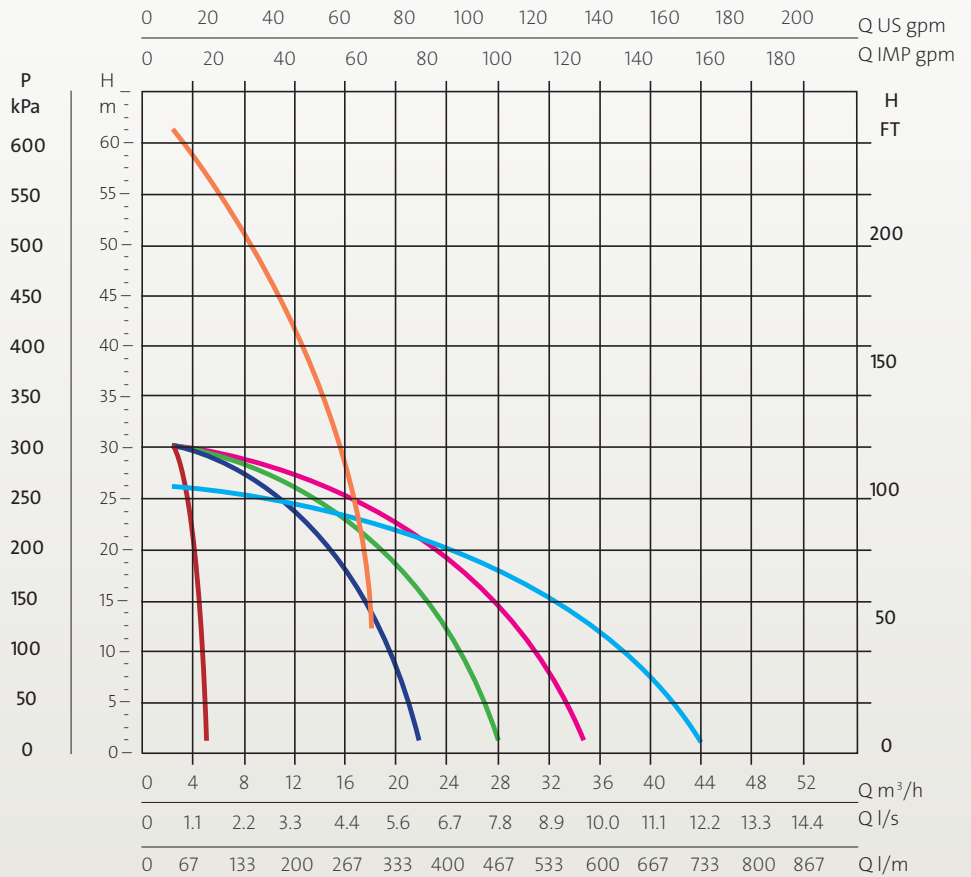

TECHNICAL DATA

Pump Model	Engine Type	Fuel Type	Start Type	Connections		Weight (kg)	Dimensions (mm)		
				Inlet	Outlet		L	H	W
FIRE WARRIOR 55/200 P	Honda GX160	Petrol	Recoil	1½" M	1 x 1½" M	24	530	420	430
FIRE WARRIOR 55/200 D	Lister K164	Diesel	Electric	1½" M	1 x 1½" M 2 x 1" M	64	790	550	580
FIRE WARRIOR WW 15/1000 P	Honda GX240	Petrol	Recoil	3" M	3" M	52	650	417	525
FIRE WARRIOR WW 15/1400 P	Honda GX340	Petrol	Recoil	4" M	4" M	68	650	499	550
FIRE WARRIOR 15/250 P	Honda GX120	Petrol	Recoil	2" M	2" M	23	475	315	400
FIRE WARRIOR 15/600 P	Honda GX160	Petrol	Recoil	3" M	3" M	27	520	370	420
FIRE WARRIOR MP 27/120 P	Honda GX25	Petrol	Recoil	1" M	1" M	6	340	250	330

ACCESSORIES

Description	Details
FIRE HOSE KIT	2 x 6 m (¾") hoses with fire spray nozzles 1 x 4 m (1½") grey suction hose with strainer

Grundfos Pumps Pty Ltd
National Phone Number:
1300 337 733

National Fax Number:
1300 782 080

Email for Sales Enquiries:
ausales@sales.grundfos.com
Email for Order Processing:
auorders@grundfos.com

grundfos.com.au

